

Chair Devils

Chair devils are wonderful tools for final shaping and smoothing of round parts such as chair spindles and posts. The specially shaped scraper blades ($\frac{1}{2}$ " , $\frac{7}{8}$ " and $1\frac{1}{4}$ " diameter) effectively round and smooth the workpiece, removing any spokeshave marks. The $\frac{1}{2}$ " blade is for spindles, the $\frac{7}{8}$ " for rungs, and the $1\frac{1}{4}$ " for legs and posts, as well as canoe paddle shafts.

The machined steel bodies are fitted with hardwood handles shaped for comfort and control when either pulling or pushing. The machined toe and the two thumbscrews are solid brass. The high-carbon steel blades are 0.040" thick, hardened to Rc48-52 and come with a finely ground 45° cutting edge.

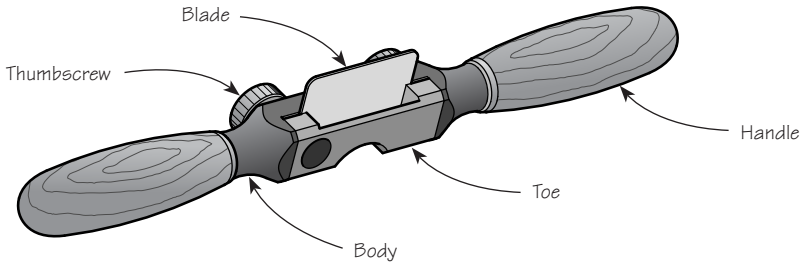



Figure 1: Chair devil components.

The chair devils can be used with either a pushing or a pulling action. This allows you to always work with the grain. This may involve frequent changes of direction, flipping the tool, and pulling or pushing as required.

Blade Adjustment

 **Caution:** Be aware that the blade is sharp; careless handling can result in serious injury.

To remove the blade, loosen the two brass thumbscrews and withdraw the blade from the tool. To install the blade, loosen the thumbscrews until there is a large enough gap between the body and toe to accept the blade. Then, with the bevel facing away from the toe, slide the blade into place. Tighten the thumbscrews.

To properly position the blade, loosen the thumbscrews so that the blade is just held in position. Slide the blade into position such that the cutting edge projects down below the sole approximately $\frac{1}{64}$ ". Tighten the thumbscrews. Test the cutting action and adjust as required.

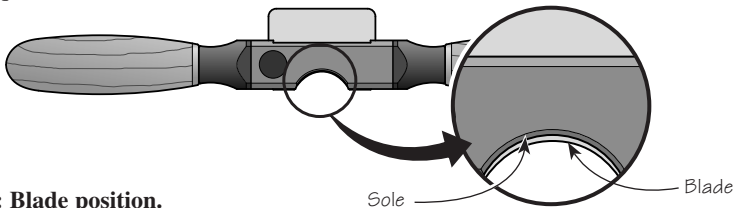

Figure 2: Blade position.

Sharpening

Step 1 – Preparation: The blade for the chair devil is precision ground at 45° and its profile matches that of the sole. To maintain its proper shape, **do not** regrind the blade until absolutely necessary (i.e., when you can no longer create an acceptable cutting edge by honing). To re-establish the correct arc, position the blade in the chair devil and scribe the profile of the sole onto the face of the blade. The best way to accurately regrind the bevel is with a simple homemade blade holder and sanding drum in a drill press. Use a 1/2" drum for the 1/2" blade, a 1" drum for the 7/8" blade, and a 1 1/2" drum for the 1 1/4" blade.

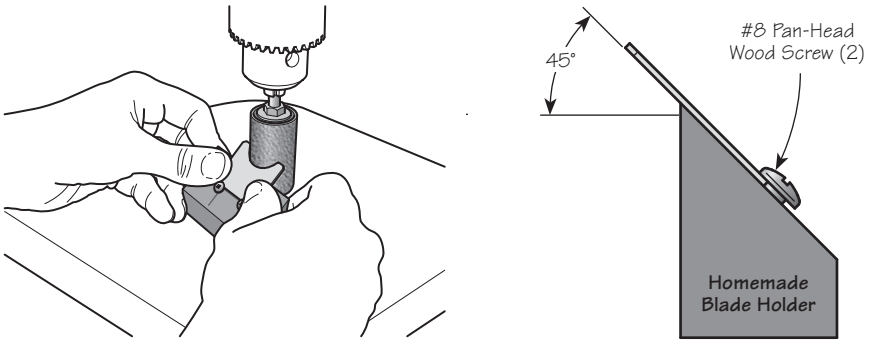

Figure 3: Grinding the bevel.

Step 2 – Honing: Use a carver's slip or a sheet of 600x sandpaper wrapped around a dowel to hone the cutting edge bevel as shown in **Figure 4**. Hone only until a fine wire edge develops. Then, as shown in **Figure 5**, lap the face of the blade near the cutting edge on a 1000x stone to achieve the same finish as on the bevel. A sharp edge can only be achieved by creating two intersecting surfaces honed to the same degree.

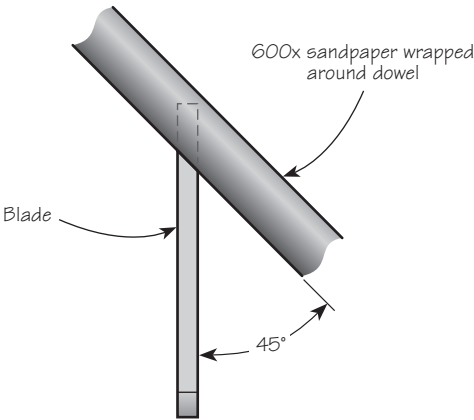

Figure 4: Honing.

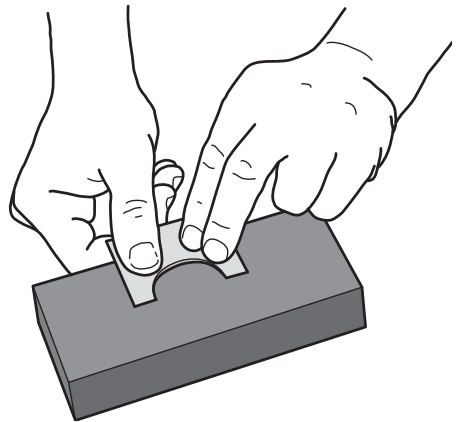

Figure 5: Lapping.

Care and Maintenance

The blade and machined surfaces on the chair devil body come treated with rust preventative. Remove this using a rag dampened with mineral spirits. Clean all machined surfaces, including the area under the blade.

We recommend that you initially, then periodically, apply a light coat of silicone-free paste wax to the sole to seal out moisture and prevent rusting (as well as act as a lubricant for smoother shaving). Wipe off any wood dust from the sole, apply a light wax coating, let dry, then buff with a clean soft cloth. At the same time, the solvents in the wax will remove any harmful oils left from your fingers that can lead to corrosion.

If storage conditions are damp or humid, your chair devil should, in addition to the treatment outlined above, be wrapped in a cloth or stored in a plastic sack. This precaution will also guard against dings and scratches.

Accessories

- 05P33.55** Replacement Chair Devil Blade, 1/2" dia.
- 05P33.56** Replacement Chair Devil Blade, 7/8" dia.
- 05P33.57** Replacement Chair Devil Blade, 1 1/4" dia.
- 05P33.20** Hardware Kit for Spokeshave Handles