

BENCHCRAFTED

Assembly and Installation Instructions

CRISSCROSS SOLO and RETRO Page 1

GLIDE LEG VISE Page 18



Version July 2021

Package Contents

Crisscross Solo

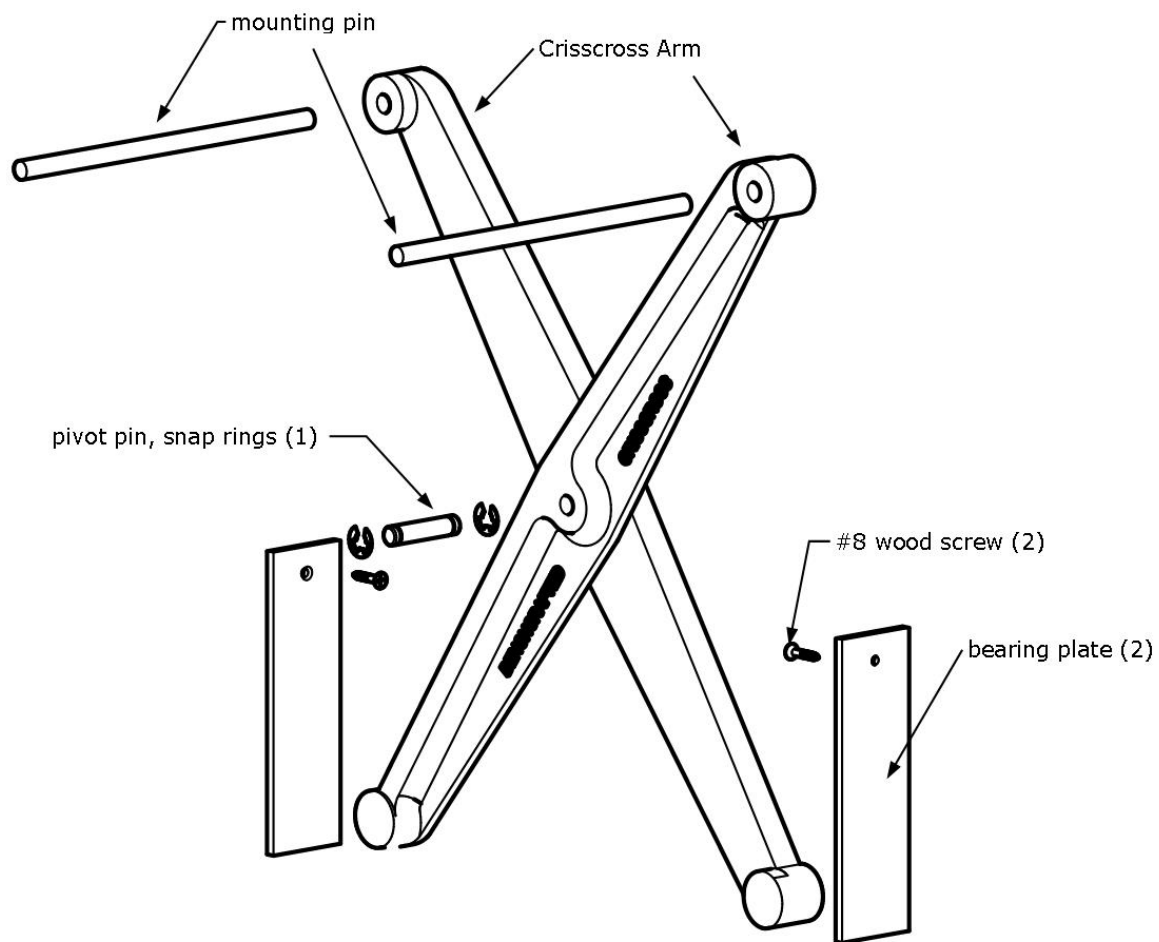

Hardware pouch contains 3 snap rings, we include an extra in case you should loose one.

Package Contents

Crisscross Retro

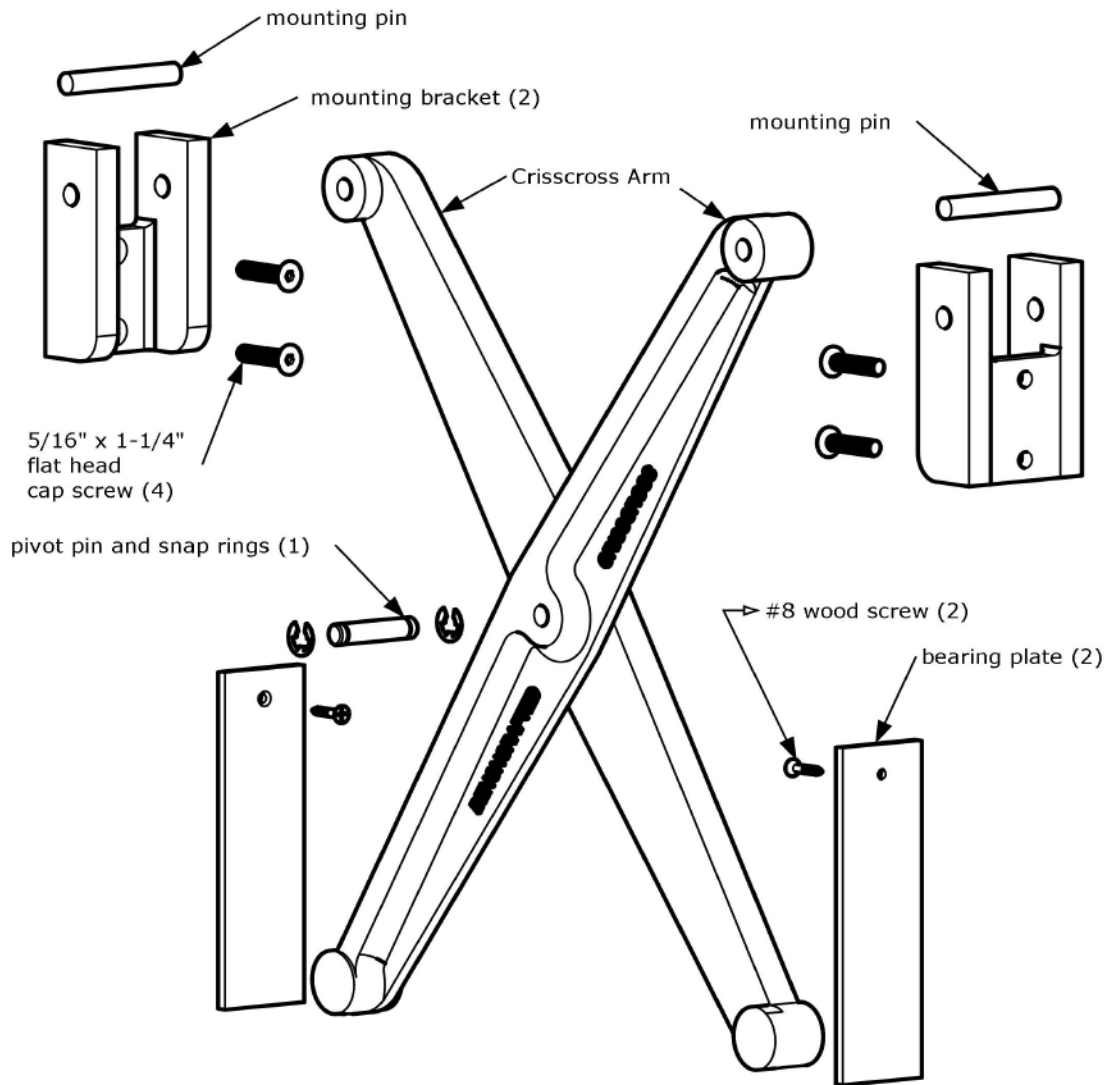

Hardware pouch contains 3 snap rings, we include an extra in case you should loose one.

! READ ME FIRST !

Read and understand these instructions **completely and thoroughly** before starting the installation or cutting into your bench project. Only begin installation once you have the hardware in your shop. There are variables explained throughout the installation process that will affect the first steps of the install. It's important that you **read through the instructions from beginning to end before you begin** to have a successful install.

UNPACKING THE COMPONENTS

Be careful as you unpack and handle the components. Although we make every effort to ease all edges, being machined parts you may encounter a sharp edge or burr, especially if the product was handled poorly by the shipper, or when unpacking your vise. If you do, ease it with some fine abrasive paper or a fine file. Some components will have a rust preventative oil applied. If excessive, you can remove this oil before installing the vise. Wipe it off with a clean paper towel with a bit of mineral spirits. This will leave a light film of oil on the parts that will help prevent rust and keep the parts moving smoothly. Dispose of oily rags in the proper way. The Crisscross arms and mounting brackets are powder coated. Sometimes this will flake off in shipping, and in use the finish will get worn off in time. You can touch up any spots with satin oil paint (available at any hardware store) but it's entirely unnecessary. The powder coating is just there to prevent rust between our shop and your's.

IMPORTANT NOTE ABOUT CRUBBER

Effective September 2021

Due to raw material shortages, Crubber is temporarily unavailable.

As of September 2021 all vises will include suede leather instead of Crubber.

We've left all references to Crubber in these instructions for those that purchased their vises before the shortage.

For those who received suede with your vise, you can treat the suede exactly like Crubber. The suede pieces can be installed in exactly the same way as the Crubber, using the same glues. Any mention of Crubber in these instructions applies directly to suede, whether it be in installation method or function.

SOLO VERSUS RETRO

We designed the Crisscross for new bench construction and called it the Crisscross Solo. Soon after, we discovered it would be difficult to drill the deep hole for the Solo's mounting pin in a leg that was part of an already assembled workbench. So we designed and manufactured special brackets so the Crisscross could be more easily "retrofit" into an existing bench without drilling those deep holes. We call this version the Crisscross Retro. Many bench builders prefer to install the Crisscross Retro, even in new benches because they prefer the installation method. The Solo is recommended for new benches only, the Retro for both existing benches or new benches.

HOW THE CRISSCROSS ARMS ASSEMBLE

The two arms join in the middle using the pivot pin and two retaining rings. We include an extra retaining ring in the package because they are easy to loose. During installation, it's best to install just one retaining ring because you'll be removing the pin and separating the arms a few times during installation. You can install the second ring after the vise is completely installed. Make sure you orient the arms the correct way during the installation. The round bosses at the top of the arms should point away from each other. See illustration below.

Correct

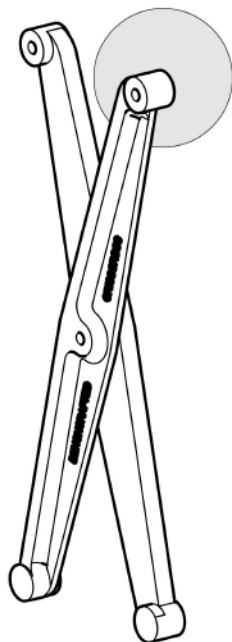

Incorrect

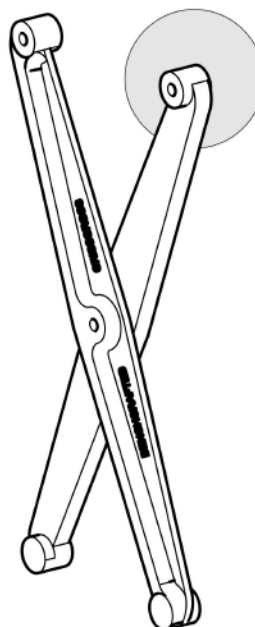

PLANNING YOUR INSTALL

The Crisscross is a simple mechanism. You can think of it as an entirely separate mechanism from your leg vise hardware. Obviously it works flawlessly with the Benchcrafted Glide or Classic Leg Vise (and our bench plans make it easy to install so you don't have to account for bench joinery), but it also works with any other manufacturer's leg vise hardware, metal or wood. In order to get the best performance from the Crisscross, it needs to work in conjunction with your leg vise, whether it be one of our's, or someone else's product. The most important factor in getting both to work together flawlessly is to ensure the in-and-out travel of the Crisscross is in line with the travel of your screw. In new installations where you're installing both the leg vise and the Crisscross together, simply follow the measured drawings at the end of these instructions to layout the holes and mortises as specified. The Crisscross, vise screw flange and nut will automatically be aligned if you follow the drawings and instructions.

But if you're retrofitting a Crisscross to an existing leg vise screw you'll need a reference point for positioning the Crisscross mortise relative to your screw. Here's how to do it:

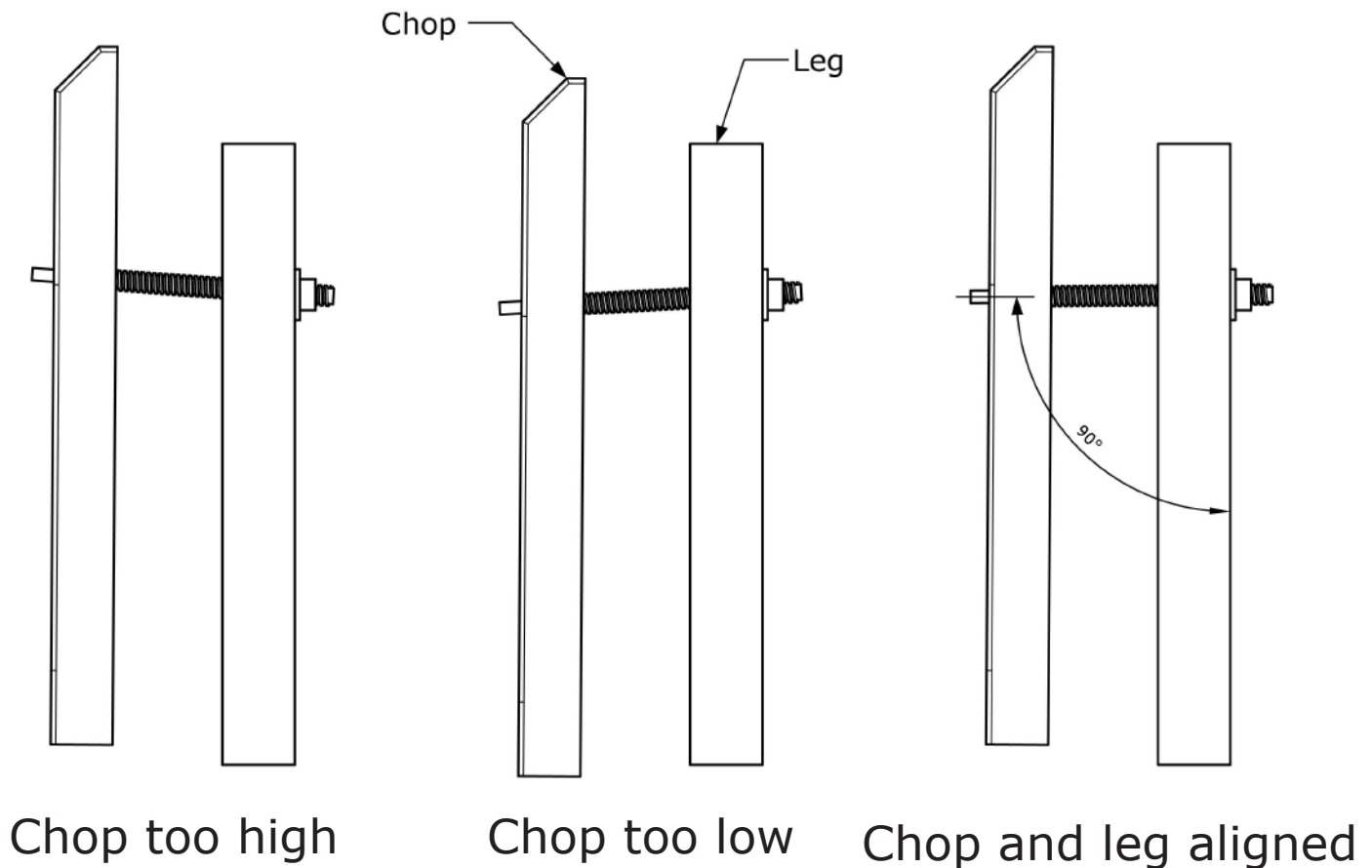

You'll need to find the vertical position of the chop relative to the leg so the screw travel is perpendicular (90 degrees, or square, see illustration above) to the faces of the chop and leg. You can find this position by shifting the chop up, marking a line across the sides of the chop and leg, then shifting the chop down and carrying the mark on the chop over to the leg (the chop will have one pencil line, the leg two) Now shift the chop so its mark is in the middle of the two marks on the leg and make a third line on the leg. This is the reference line you'll use to layout the Crisscross mortise from. Carry this line onto the inside faces of the chop and leg. If you find that you need to make an entirely new chop to install the Crisscross with your leg vise hardware, you can simply use the center of the existing hole in your bench leg as the reference, and layout the locations of the Crisscross mortises and hole in your new chop based on that. Make sure you keep your chop extra long at the top. You'll cut it to final length, flush with the top of the bench, later.

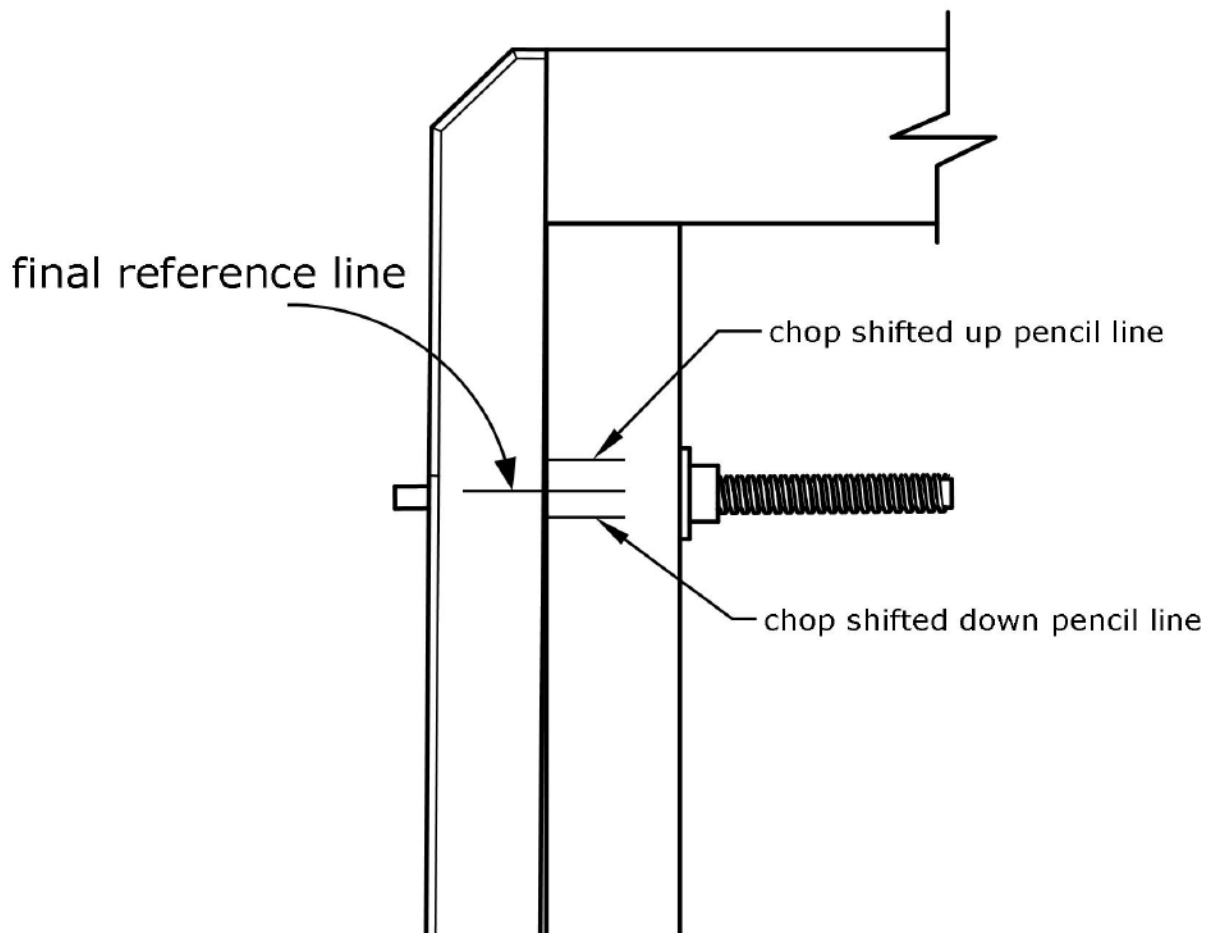

The Crisscross occupies 19-1/2" of vertical space in your bench leg and chop. You can position the Crisscross anywhere you like vertically (it should be centered left-to-right in the leg and chop, directly below the vise screw.) It's best to install the Crisscross in the lowest possible position on your bench leg. This allows you to also mount the vise screw in a lower position, giving you the greatest possible clamping capacity above the screw. Ideally, we like to keep about 1" of material below the Crisscross mortise at the bottom of the leg and chop, but if your situation dictates that your mortise be open all the way to the floor, this does not present a problem. The Crisscross will open to a maximum of about 16", but this is governed by the length of the vise screw. You should not mount the Crisscross Solo in a bench leg that's narrower than 3", or the Retro in a leg narrower than 4". Bench leg and chop each need to be at least 2-1/2" thick (you could go thinner, at your own risk.) You don't need thick stock, you can laminate 8/4 stock onto 4/4 stock to achieve that thickness. Position the glue lines towards the inside face so the mortise floor falls within solid stock (not on a glue line.) The chop can be as narrow as 5", but you'll get better grip if you make it around 8" wide at the top. You can cut any design you like onto the sides of the chop--tombstone shape, coves and curves-whatever (the design we show here is just one possible shape) just save that step for the very end.

To layout the Crisscross mortises, refer to the measured drawings at the end of these instructions. It is not necessary for the Crisscross to be a specific distance below the vise screw (but remember to allow enough for the acetal bushing if you're using one of our Benchcrafted leg vises.) The location on the drawing is simply a lowest position of both the Crisscross and vise screw together in a given bench height. You can shift both the Crisscross and your vise screw locations up or down to suit your bench (Dimension "X") Layout everything in full size before you cut anything.

Four points to consider when determining where to vertically position your Crisscross:

1. The space below the Crisscross mortise: ideally, you don't want the mortise to be open at the bottom of the leg. Best to keep some material here. 1" minimum. Although if you have a wide and thick leg (5" or more) an open mortise won't pose any problems. Make sure you chamfer the end of the mortise so you don't blow out material if you drag your bench across the floor.

2. The distance between the top of the Crisscross mortise and the vise screw: Leave a little material between the screw and the mortise for strength. You can get a bit closer with the Solo. If you're installing a Glide Leg Vise, the drawings show the ideal distance below the acetal bushing.

3. Height of the bench: If you have a tallish bench of 36" or so, you might want to move everything up a little. The drawings show, again, lowest possible position. This makes for a lot of room above the screw, but you might want to reduce this so you're not bending over too much to grab the vise handle.

4. Possible interference with an upper rail and/or the benchtop: If you position your vise and Crisscross without regard to upper rails running between your front and rear legs, or the benchtop itself, you might find either part ending up where the vise's nut needs to be, especially if your nut has a large flange, or you're using a thick wooden nut. This is especially important in very short benches. If you are retrofitting a Crisscross and have less than about 20" below the screw, you may need to move the entire vise up to accommodate the Crisscross. Again, layout in full size before cutting or drilling.

TIME TO CUT SOME WOOD

Once the location of the Crisscross has been determined for your bench, and all the layout work has been done, it's time to cut the leg and chop to receive the Crisscross Solo or Retro.

Crisscross Solo only

First, drill the two 3/8" holes in the chop and leg for the mounting pins. Use a drill press for maximum accuracy. If you don't have a drill press or aren't confident drilling these deep holes, you should use the Retro version of the Crisscross (contact us if you'd like to buy Retro brackets for your Crisscross Solo.)

Tip: when drilling deep holes use a sharp, high quality bit and back the bit out frequently (every 3/4" at most) to clear chips. You should drill clear through the leg and chop to make installation easier should you need to tap the pins out from the opposite side.

Crisscross Solo and Retro

Now cut the 1-7/16" deep mortises in the chop and leg. Note that the Retro mortises have a wider section at the top to accommodate the Retro brackets (see the dotted lines on the drawing.) The Solo mortise is just a long rectangle. We like to hog out most the waste on a drill press with a Forstner bit, then clean things up with a plunge router and edge guide. But a chisel can do the same work if you prefer.

Below is an illustration of the mortise and mounting pin holes for the Crisscross Solo (illustrated on a chop) and the mortise for the Crisscross Retro (illustrated on a leg.) The holes for a Benchcrafted leg vise (Glide or Classic) are also illustrated here for reference. If you're using other hardware, your holes may look different.

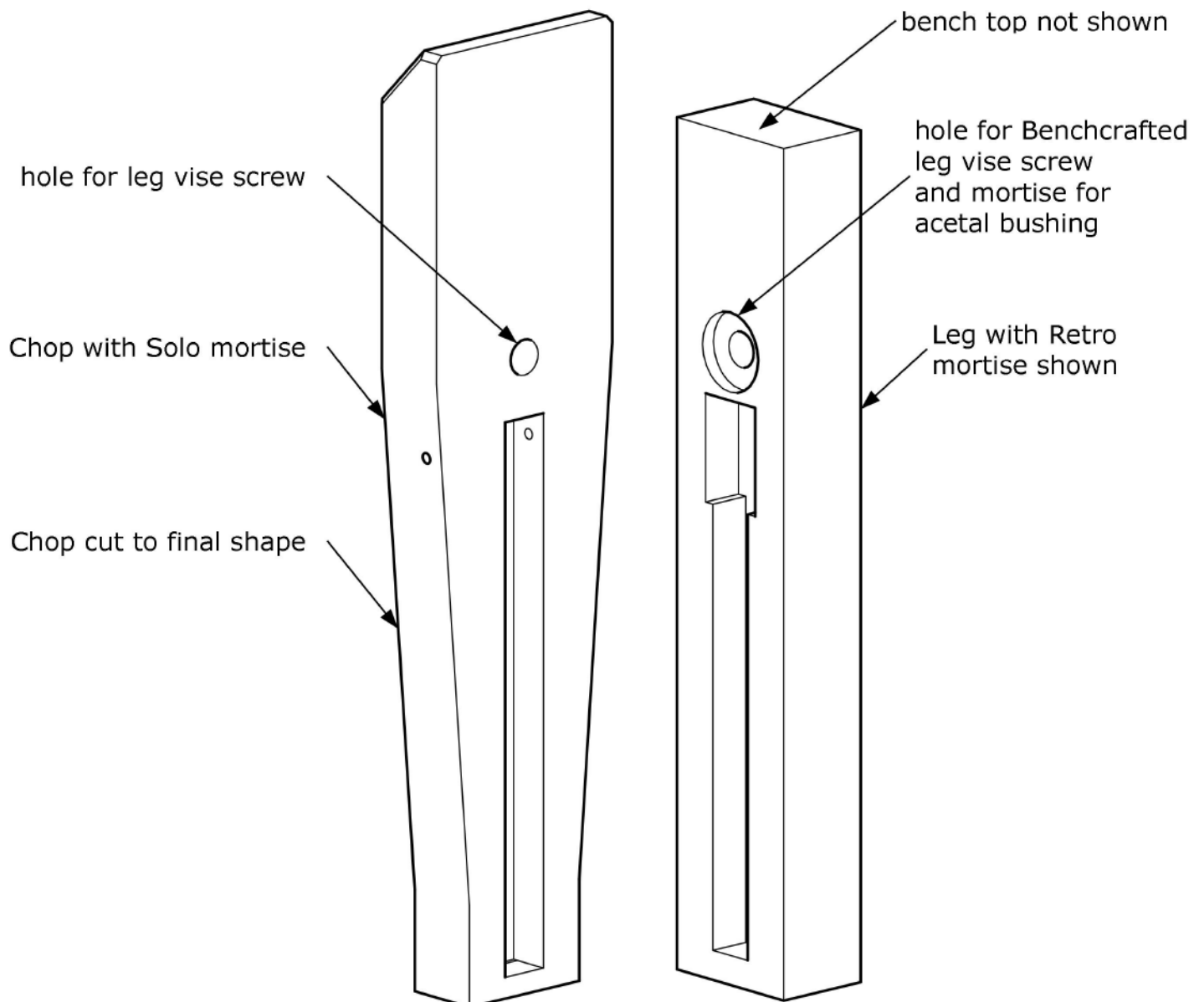

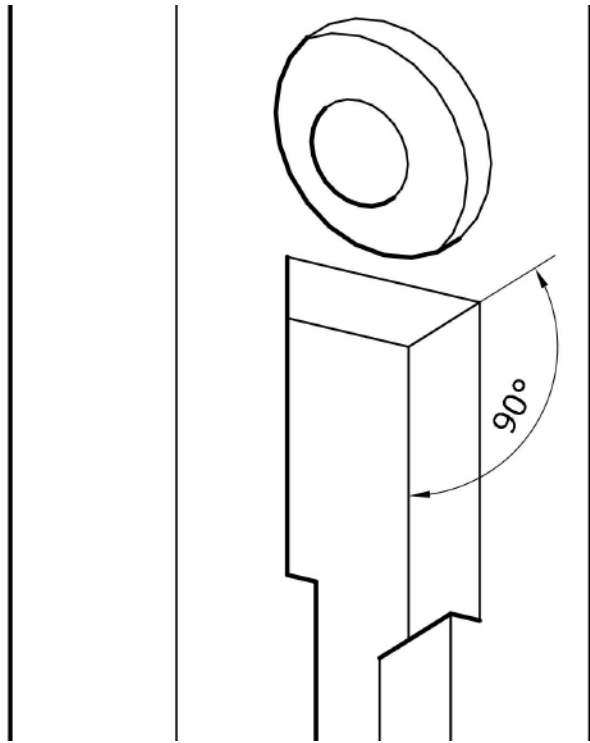

It's important that the back and top surface of the Retro mortise (where the machined surfaces of the bracket bear against) are perpendicular to each other. See illustration above.

Once the mortises are cut, install a bearing plate into the bottom of each mortise: one in the leg, and one in the chop. They DO NOT get mortises of their own, but simply mount to the back surface of the Crisscross mortise with the single screw.

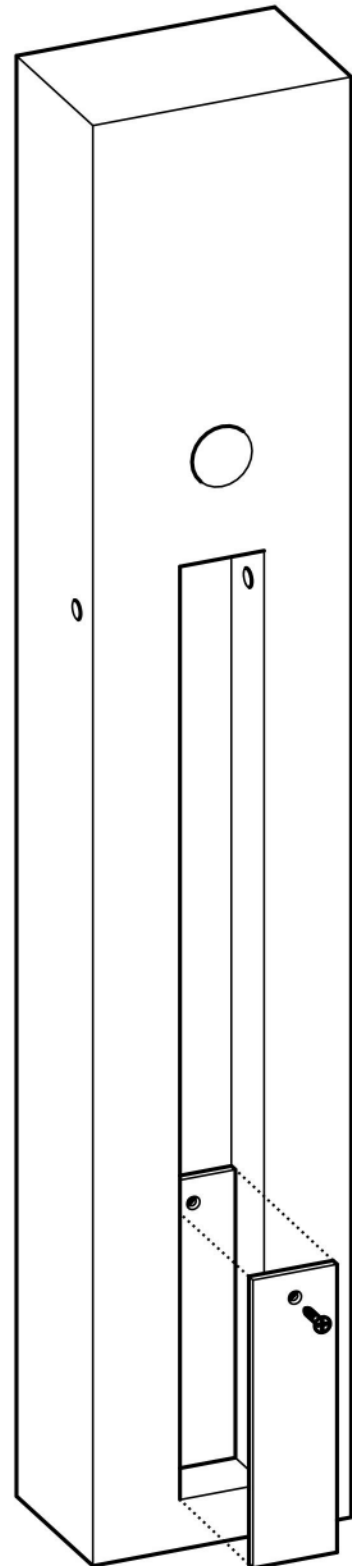

Crisscross Solo (skip ahead if you're installing the Retro version)

For this next step it's handy to have the leg mounted rigidly to a workbench so you can test the action. It can be clamped with a long clamp to a benchtop, or held in a vise if you already have a workbench to use.

Now install the arms into the leg and chop by tapping the mounting pins into the holes until they poke through into the mortise a little. Slip each arm onto the pin and continue to drive the pin until it enters the opposite side about an inch. You don't need to drive it all the way through the leg at this time. Slide each arm on its mounting pins so its up against the mortise wall with the flat back facing center. Make sure you have them oriented correctly (see page 4.) Once the arms are installed, bring the chop to the leg, swing the arms together until the pivot holes line up, then insert the pivot pin (it should only have one snap ring on at this point.)

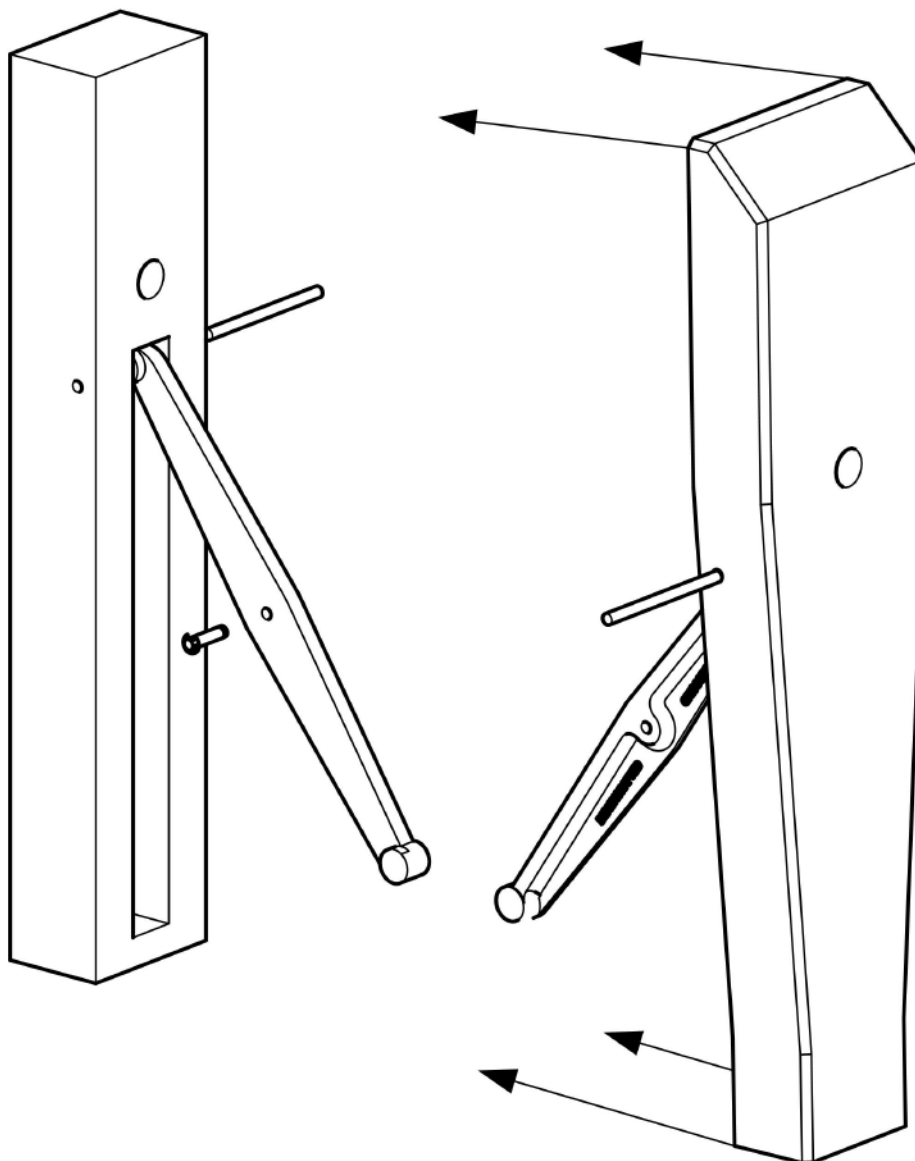

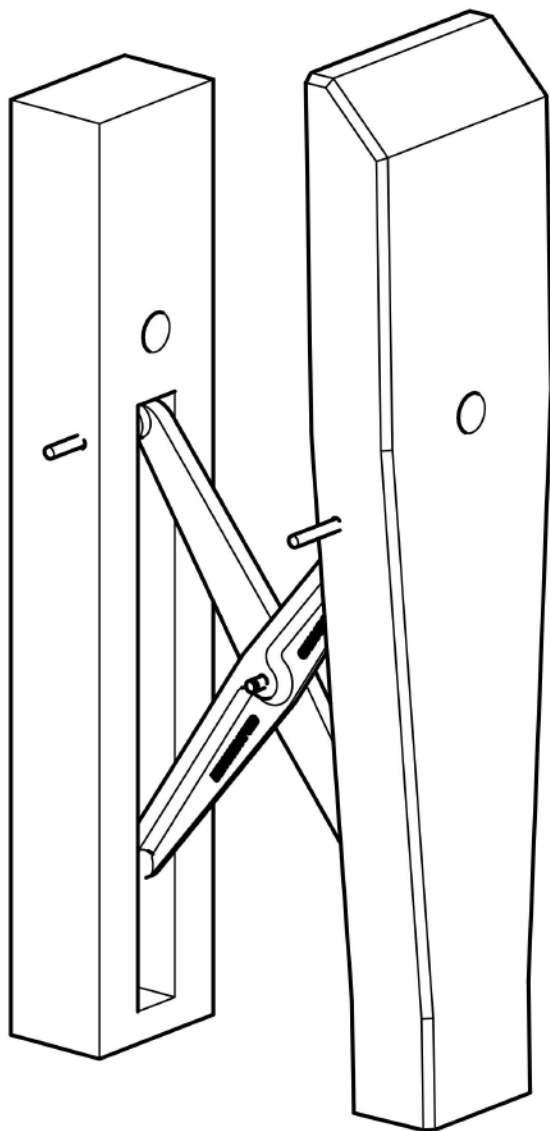

TEST THE ACTION

If you haven't already, clamp the leg upright in a vise or to a bench top so it's held securely. The chop should glide or "float" smoothly as you open and close the chop. If it doesn't, make sure the arms aren't rubbing tightly against wood in the sides of the mortise. The arms will generally find their own center after a short time.

CHECK THE TOE-IN

Toe-in is when the chop contacts the very top of the leg (or ultimately the top of the benchtop) first. You want some toe-in. It is essential for holding the work securely. If there is no toe-in (chop closes dead parallel to the leg), or negative toe-in (gap at the top) you should make some adjustments to get some toe-in.

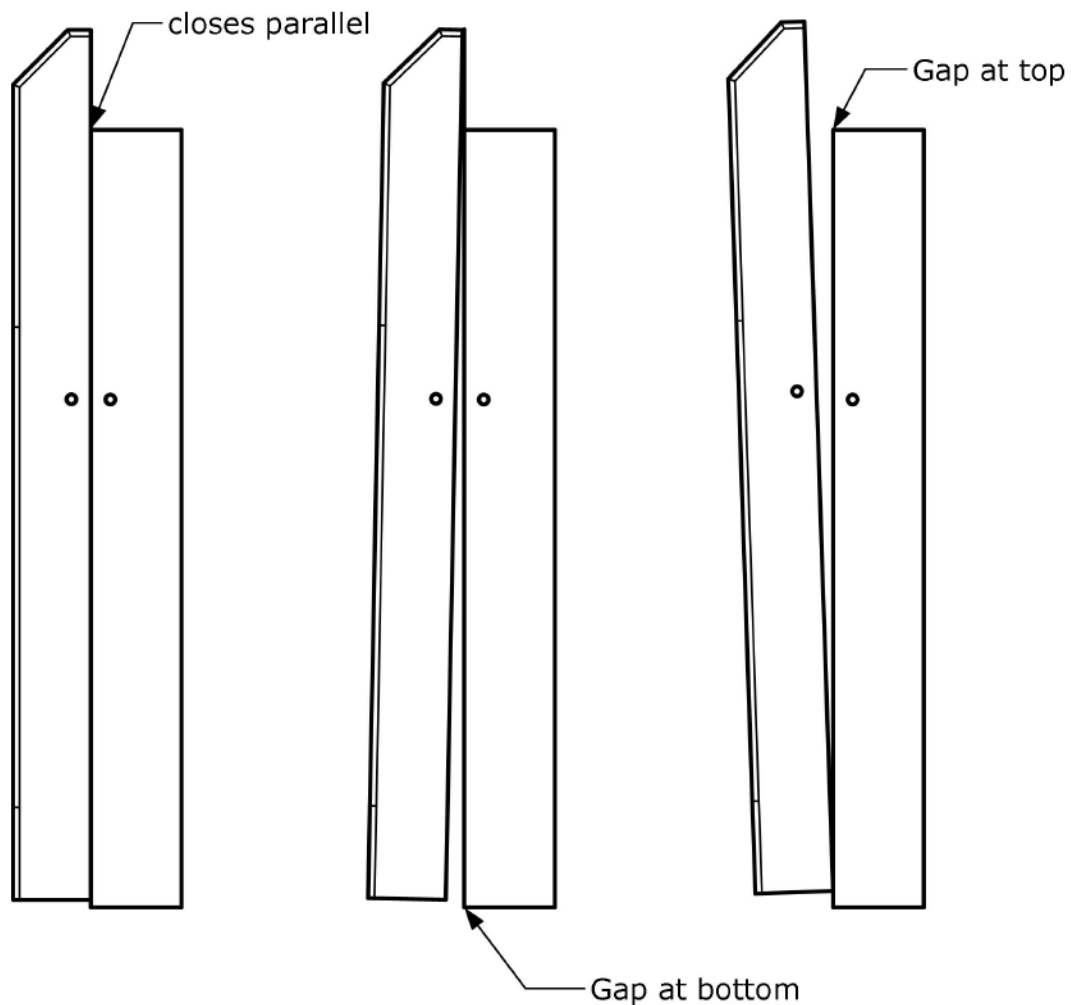

No Toe-in

Correct Toe-in

Negative Toe-in

If you have too much toe-in, it can cause the screw's flange to bind on the shaft. To reduce the toe-in in this situation, you'll need to remove the bearing plate from the chop, then remove some wood from the mortise so the bearing plate sits deeper in the chop's mortise. Start off with making the mortise 1-5/8" deep behind the plate (so adding 1/16" to the normal depth.) Reassemble and evaluate. Go deeper if necessary. If you have no toe-in, remove the bearing plate in the chop and slip a piece of veneer, or some dense cardboard behind the plate, this will tilt the chop and create some toe-in. If you have negative toe-in, the process is the same, add a shim behind the chop's bearing plate. If negative toe-in is excessive, you may have drilled your mounting holes too close to the inside faces of the vise. Plug the holes and/or reposition the Crisscross up or down (you'll have to adjust the mortise length too) so you can drill correctly positioned holes. These methods work for adjusting your toe-in, but they can all affect the smoothness of the vise's action, especially if you go too far with an adjustment. If you find you have zero or negative toe-in, but the vise is operating

sweetly, the best course of action is to dismantle the vise and plane a taper onto the inside face of the chop so it contacts at the top first. This gives you the toe-in you're after without affecting the mechanical action of the vise.

There is no magic number for determining the gap at the bottom for correct toe-in. 1/4"-3/4" can work fine. If the jaw contacts first at the top, and holds well, you're good to go.

TIP: To remove a mounting pin during installation, use a smaller pin (we use a long phillips screwdriver) to tap it out. The smaller pin will catch the hole in the Crisscross and keep the arm engaged with the chop/leg. You can now pull the smaller pin out easily since it's loose in the hole and safely remove the Crisscross arm from the mortise.

Now you can cut the mounting pins to final length and smooth the ends for a finished look. We like to chuck the pins in a drill and run the ends against a piece of sandpaper. Next, install your vise hardware. If you're installing a Benchcrafted Glide Leg Vise, you'll find the instructions a few pages ahead. Even if you're installing non-Benchcrafted hardware we recommend you read through the section on mounting the nut in the Glide instructions that follow. It will help you install any vise screw properly.

Crisscross Retro

For this next step it's handy to have the leg and chop flat on your benchtop or worksurface.

Place a bracket in the mortise and press it tight to the upper end of the mortise (where it butts into end grain) and while holding it tight, use a transfer punch or awl to mark for the two mounting screws. Try to bias the location slightly towards the upper end of the hole in the bracket, so as you install the screws the bracket will be drawn tight to the upper end of the mortise. You can see why its important to layout your mortise carefully, since the end of the mortise here, where you chopped it square, determines the vertical position of the Crisscross and the alignment of the arms to each other. Be diligent to get everything correct here. Take your time and work with care and attention. Drill and tap for the 5/16"-18 mounting

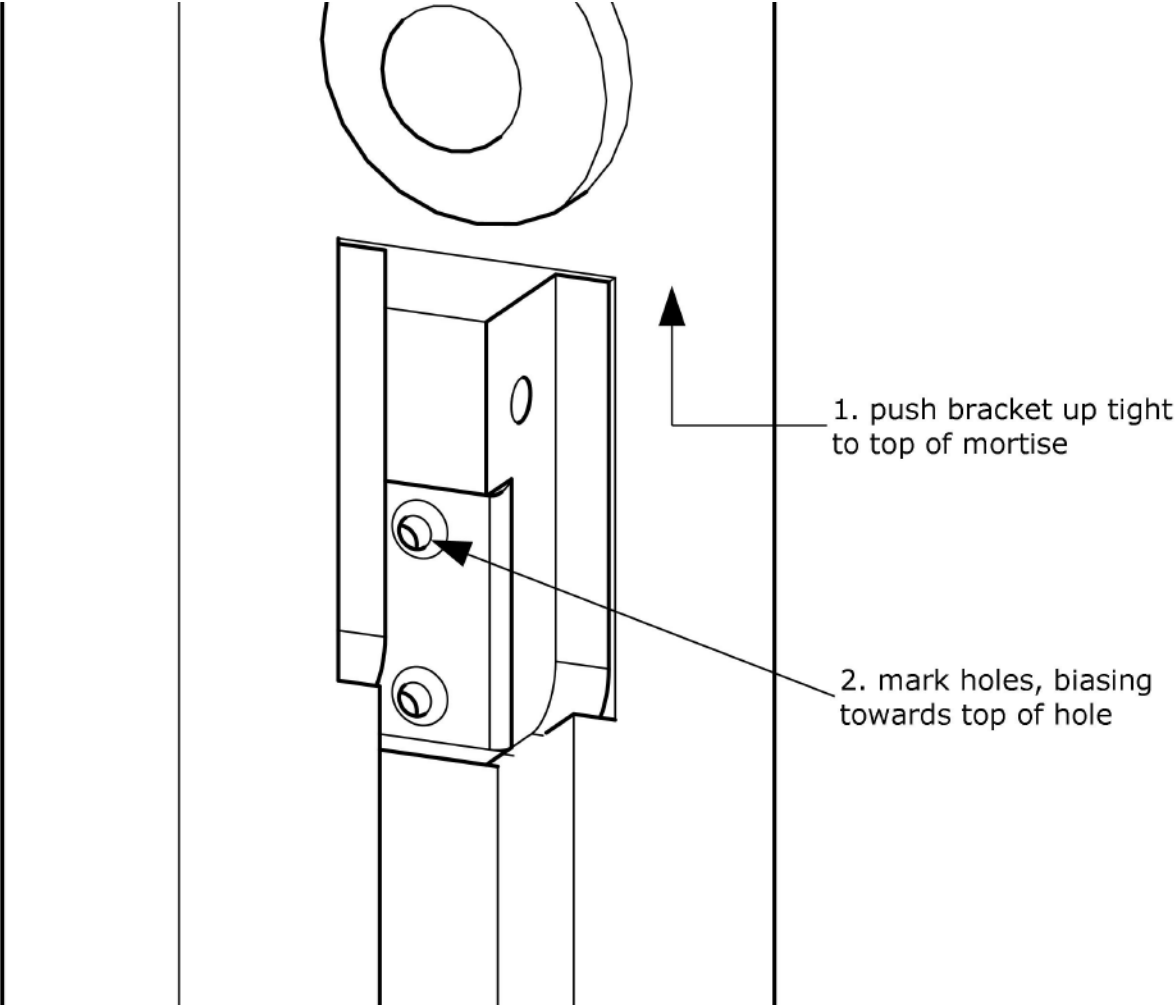

screws. (See the addendum at the end for info on tapping wood for machine screws) Then test mount both brackets in the leg and chop by threading in the screws. After you've determined that they fit properly you'll need to remove them to install the arms.

To mount the Crisscross Retro, first join each arm to the brackets with the 2-1/2" mounting pins. See the illustrations below to get the orientation correct. The pins just slip in place and fit loosely and rotate with no resistance. These are held in place by the walls of the mortise, and once the bracket is installed, they are trapped in place. Now place the bracket and arm assembly in the mortise and drive the two mounting screws. You'll need to swing the arm up and out of the way to access the mounting holes, see illustration below right.

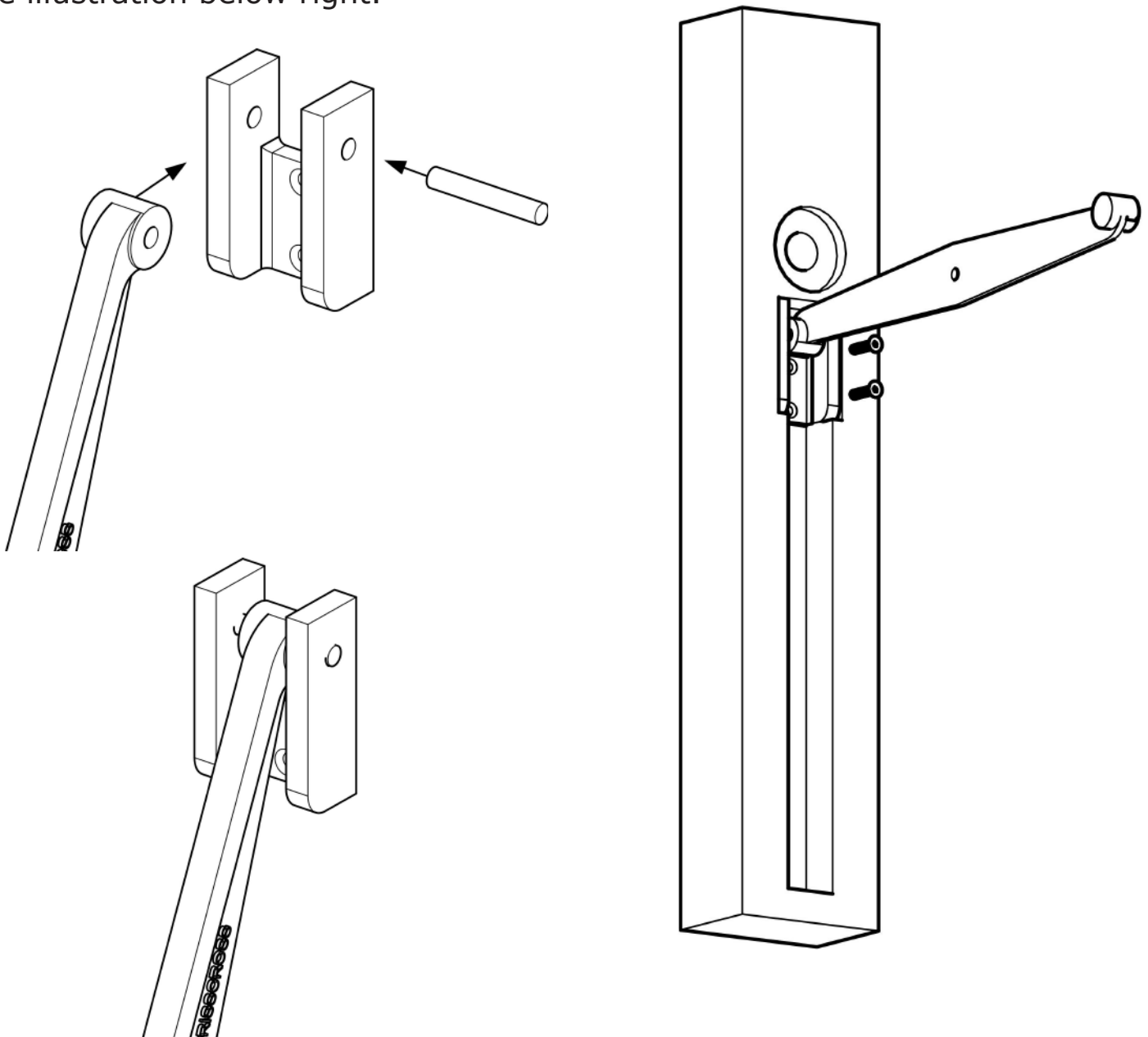

Mount both assemblies to the leg and the chop. Get ready to test the action of the assembled Crisscross Retro. If you're building new, clamp the leg in a vise or against a bench so you can test the Crisscross action in the proper upright position and with the leg held rigidly. Place the pivot pin in one of the arms with only one snap ring installed (leaving one snap ring off lets you test fit and disassemble easily during the installation process.)

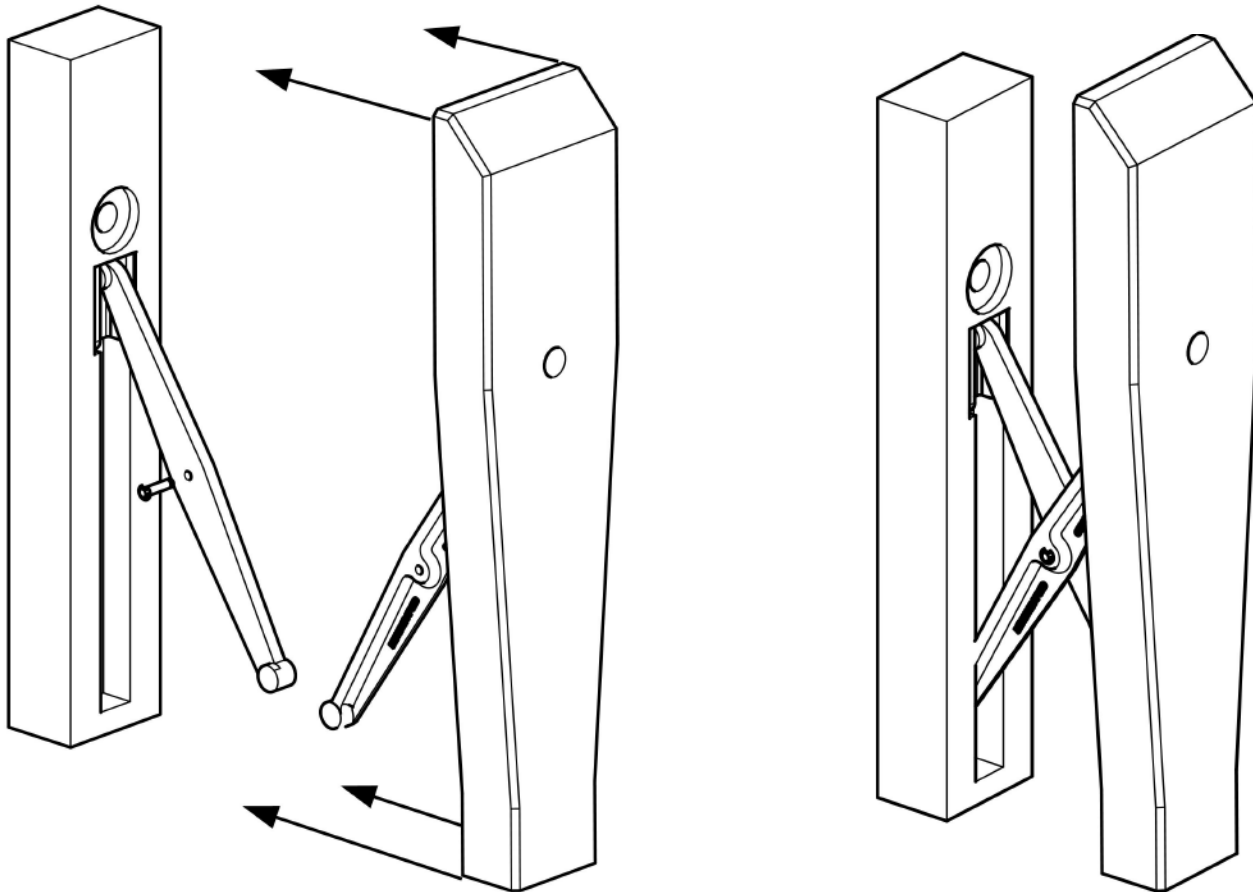

Now swing the arms together, flat back to flat back, until the central pivot pin holes align. Push the pin into the other arm. The chop should now "float" in and out quite easily as the Crisscross supports the weight of the chop. Now check the vise for proper toe-in (see previous section.) If you're retrofitting the Crisscross to a bench with existing vise hardware, you can now reinstall those components and test the action of the vise. If you did your layout carefully the vise should work sweetly. You can now cut the chop to final length and shape and install the jaw liner material you like. We recommend our Crubber, which is available on the Benchcrafted website. If you're installing a Benchcrafted Glide Leg Vise, you'll find the instructions below.

GLIDE LEG VISE INSTALLATION

Package Contents

Glide M or C with Crisscross Solo / Retro

Not pictured:

- Groove pin (1+1 extra)
- #10 round head wood screw (3, for nut)
- #8 round head wood screw (3, for acetal bushing)
- 5/16-18 x 1-1/2" flat head machine screws (2)
- Nylon washer for knob attachment (3+1 extra)

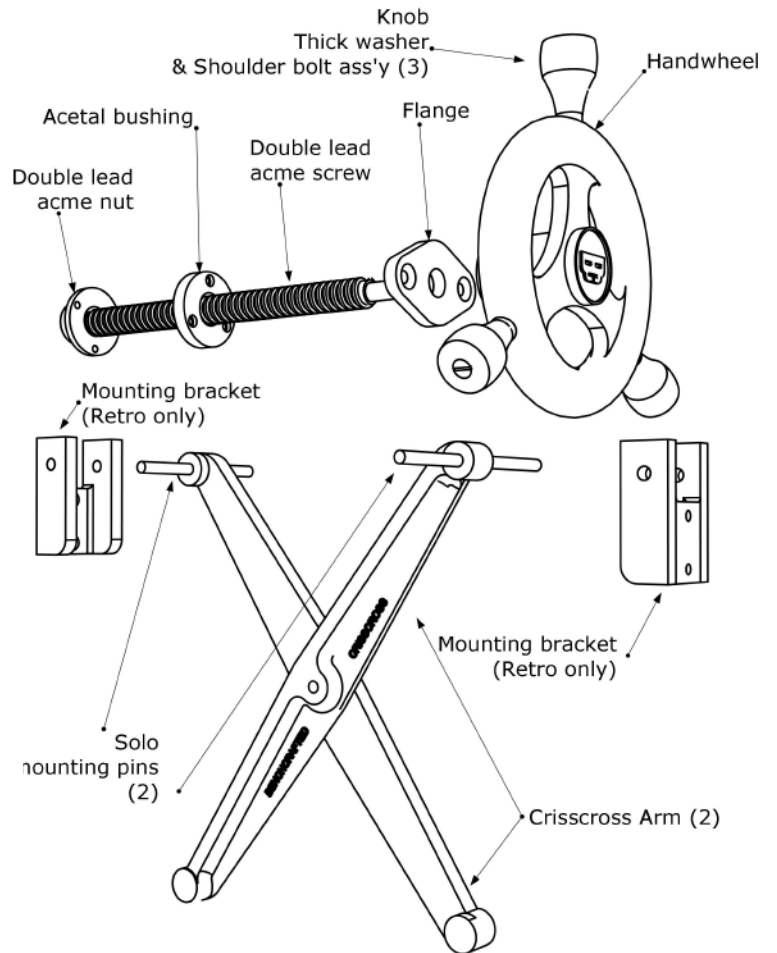
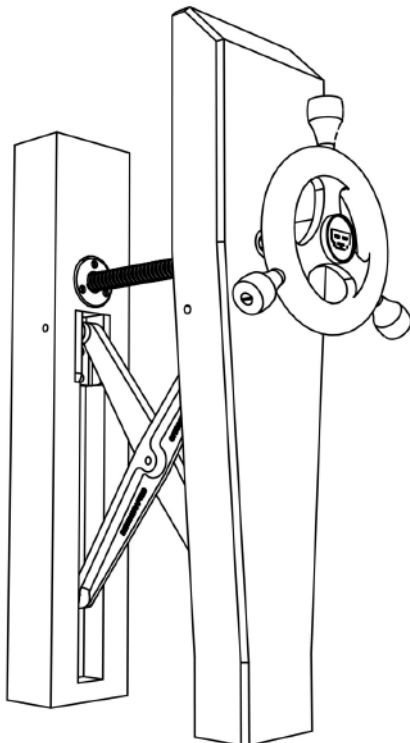

ATTENTION!

Read and understand these instructions COMPLETELY AND THOROUGHLY before starting the installation or cutting into your bench. We highly recommend that you NOT begin installation without the Crisscross, Glide and all other bench hardware in your possession.

UNPACKING THE GLIDE

Be careful as you unpack and handle the components. Although we make every effort to ease all edges, being machined parts you may encounter a sharp edge or burr. If you do, ease it with some fine abrasive paper or a fine file. Some components will have a rust preventative oil applied. You can remove this oil before installing the vise. Wipe it off with a clean paper towel. This will leave a light film of oil on the parts that will help prevent rust and keep the parts moving smoothly.

ASSEMBLY

The Benchcrafted Glide Leg Vise ships unassembled. You will need to install two parts onto the acme screw's shaft: the flange and the handwheel. It only takes about a minute.

Tools required:

Small hammer

1/8" punch

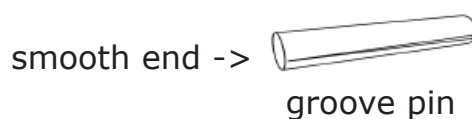

1. Get the handwheel, flange, acme screw, and groove pin.
2. First, place a couple drops of light oil on the shaft end of the acme screw near the shoulder for lubrication, then slide the flange onto the shaft.

IMPORTANT: Face the side with the two countersunk holes away from the screw. The countersinks need to face OUT once the flange is mounted to the chop. Refer to the illustrations found in these instructions.

3. Slide the handwheel onto the shaft, lining up the cross hole in the hand wheel's hub with the cross hole in the shaft. Peer down into the hole and position the handwheel until the two holes line up precisely. You'll notice two sets of holes on the shaft. **Use the hole closer to the screw for the Glide.** The other hole is for our Classic Leg Vise.

4. Get the groove pin, punch and hammer. Examine the groove pin. One end is smoothly round, with virtually no grooves. The grooves get wider as they reach the opposite end of the pin.

6. Insert the SMOOTH END WITH NO GROOVES first into the cross hole in

the hub and with finger pressure insert the pin until you feel it engage the hole in the shaft. If you can't insert it far enough with finger pressure, use the hammer to lightly tap the pin to get it moving towards the shaft. Try to keep the hub in line with the cross hole in the shaft as you tap the pin in.

7. Keep tapping the pin in until you feel a little resistance as the pin meets the hole in the shaft. Tap some more until you feel the pin engage the hole in the shaft. Now take the pin punch and place it on the head of the pin and finish driving the pin through the shaft and the opposite side of the hub until the pin is centered in the handwheel's hub. Use light taps. The fit is machined precisely, it doesn't take much force.

8. The flange should now spin freely on the shaft and have a little bit of play in the fit. The pin itself may fit loosely. If you'd like to tighten it up, it's easy. Put the pin in a metal vise with about half of the pin exposed past the jaws, then tap the exposed end with a hammer a couple times to put a slight bend in the pin. Easy now, just a slight bend. This will keep the pin in place when you assemble the handwheel.

See the section "Final Steps" for info on installing the knobs, which you should do after the entire vise is installed.

GETTING STARTED

The Glide Leg Vise works in tandem with our Crisscross Solo, Retro or Crisscross 14. The first step to install the Glide is to install the Crisscross, which is why we include both instructions together. Start on page 1 of these instructions to install your Crisscross, then find your way back to this point to finish the Glide installation.

These instructions cover the Crisscross Solo and Retro only. If you're installing a Crisscross 14 please follow those instructions, then come back here to finish the Glide installation.

TIME TO DRILL SOME HOLES

You'll need to drill two holes to install the Glide. One in the chop, and one in the leg. The hole in the leg will also get a counterbore at the front to accept the acetal bushing. The locations of these holes and the sizes are illustrated at the end of the instructions on the measured drawings, as you discovered when you laid out for the Crisscross. The finished holes are illustrated below:

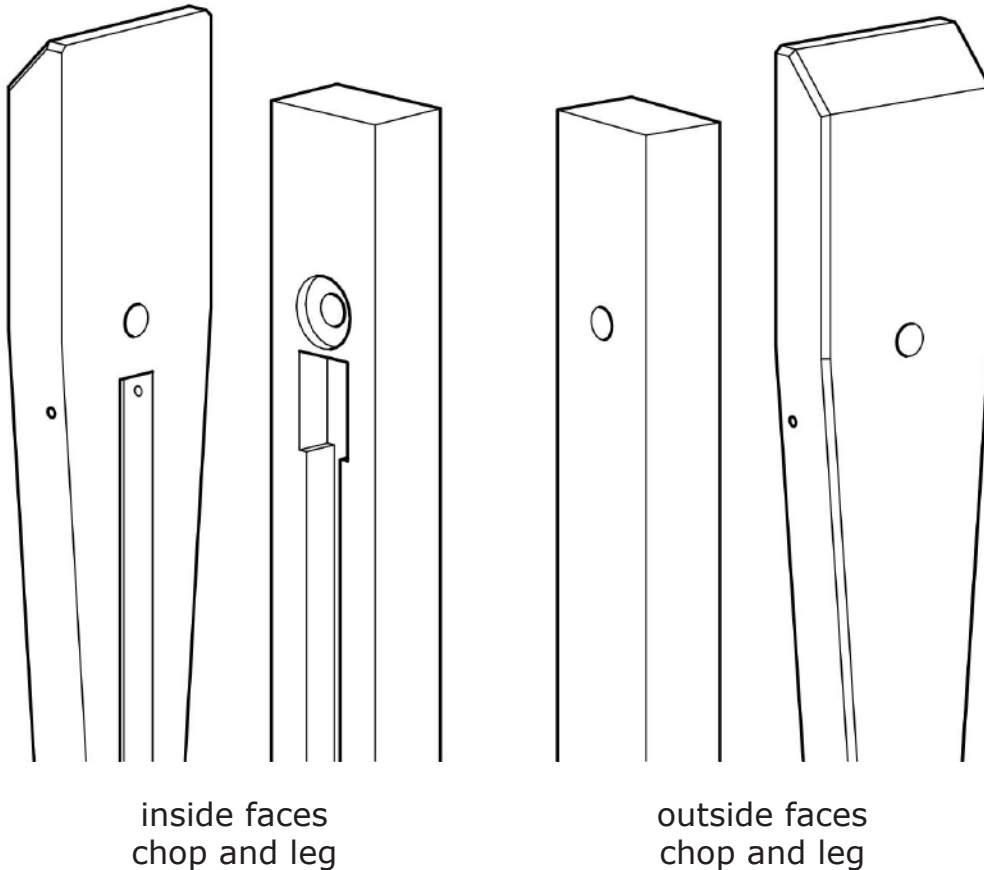

You'll want to drill these large holes from both sides of the leg and chop to prevent blowout. You can drill almost all the way through from one side, letting just the very center point of your drill bit poke through the back. Then flip the piece and finish drilling, using the tiny hole as a guide.

If you don't have a large 2-3/4" drill bit to cut the counterbore for the acetal bushing you can use a router to make the cut. You can make a circle template and use a pattern bit or template follower. The hole doesn't need to be an absolute perfect circle, you're just getting material out of the way here.

MOUNT THE FLANGE

Place the chop on a flat surface for this next step. To mount the hand-wheel assembly to the chop, place the screw through the hole and center the screw in the hole. To do this, first draw a horizontal line across the face of the chop, centered on the screw hole. Place the assembly in the chop and line up your assembly so the horizontal line is running through the middle of the two holes in the flange. This centers the screw vertically in the hole. For horizontal positioning, shift the entire assembly to the left within the hole until it stops, now mark the position with a pencil line at the edge of the flange. Now shift the assembly to the right until it stops and mark another line at the edge of the flange. Now move the flange until its centered between these two marks. Make

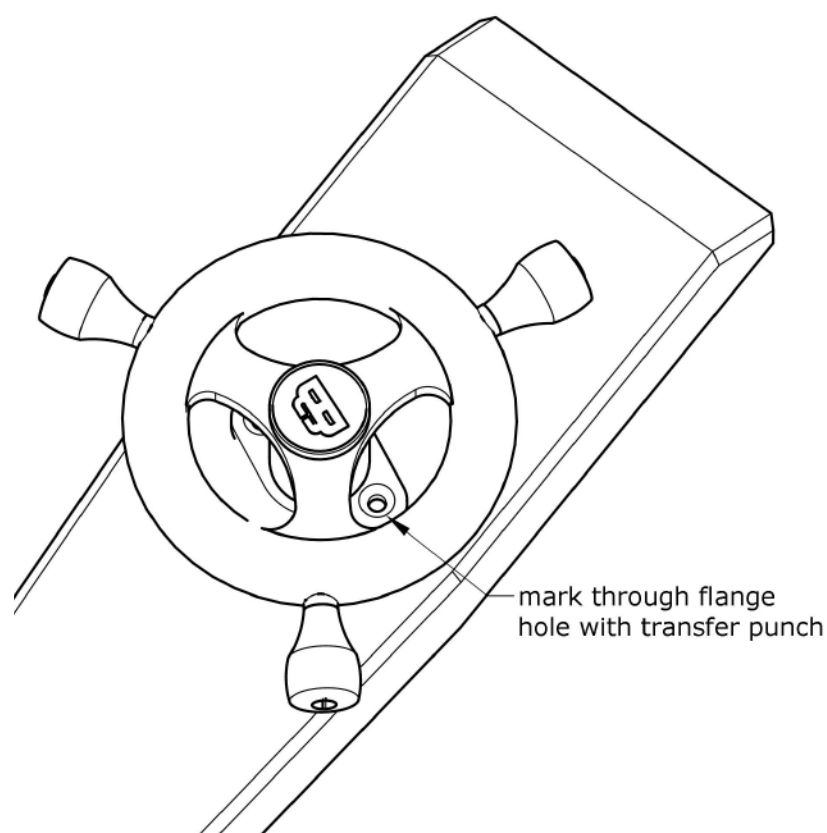

sure the flange is still centered vertically on your horizontal layout line. You **MUST** be certain the screw is centered in the hole and not touching the chop at all! If the screw is touching wood it will slow the vise down and not spin freely. While in this centered position, mark the hole centers with a transfer punch, center punch or awl (see illustration) You will need to carefully rotate the handwheel to access the holes without moving the position of the flange. Now remove the handwheel assembly by lifting it out of the hole. Using a 1/4" bit, drill pilot holes for

the 5/16-18 tap. Tap the holes for the 5/16 flat head machine screws. (See the addendum for tapping techniques in wood.) Once the holes are tapped, replace the assembly in the chop, screw the flange in place and check to see that the screw spins freely. The vise screw should not touch the walls of the hole at all, and the wheel should rotate freely.

MOUNT THE NUT

Next, you need to position the vise's nut and fasten it to the bench leg. Here's how to do it. Clamp the bench leg firmly to something rigid for this step. Reassemble the chop to the leg by joining the Crisscross arms and inserting the pivot pin. If you removed the flange/handwheel/screw assembly from the chop, reinstall it now. The screw should now be passing completely through your bench leg. Thread the nut onto the screw until it gets close to the back of the leg. Now with one hand, press hard on the face of the handwheel directly in line with the center of the screw. This will push the chop closed, forcing the inner surface of the handwheel's hub to seat flat on the outside of the flange, positioning the screw into a closely parallel orientation with the Crisscross. As you're pushing in, you can observe the end of the screw raising up and finding its center within the leg's clearance hole. It must not touch any wood in the chop or the leg. This will slow down the action of the vise. If it touches wood, enlarge the hole until it doesn't. While still pushing in, tighten the nut against the back of the leg with your other hand until snug. If your vise chop has a lot of toe-in your screw will point more towards the floor. Keep this in mind during the next step. While holding the nut in position firmly with one hand (pressing against the back of the leg) slowly operate the vise. Try not to move the nut. If the vise operates smoothly, close the vise carefully until the nut is again snug against the back of the leg. If it doesn't operate smoothly, try shifting the nut around to find a spot where the vise does operate smoothly. What you're doing here is finding the sweet spot where the screw is running nicely inside the nut. This will allow the vise to operate at its peak.

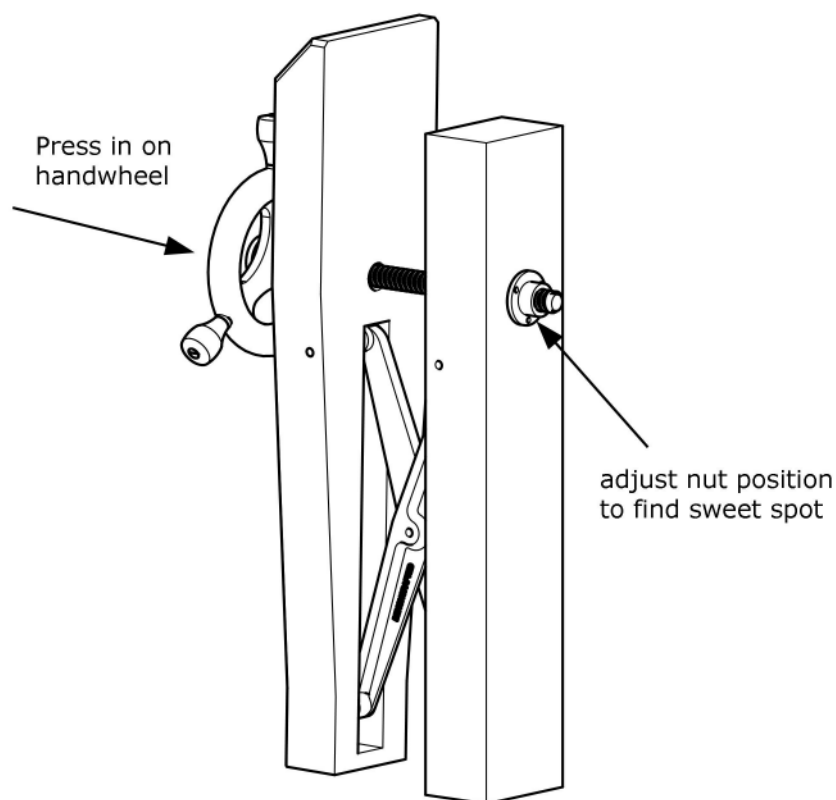

When you're satisfied with the nut position and action, tighten the handwheel enough that the weight of the screw does not drop down and spoil the location of the nut, then mark the leg through the nut mounting holes for the mounting screws. Also mark the nut itself so when you install it, its in the same orientation as before (a dot at 12 o'clock is what we do.) Now remove the nut, drill the pilot holes for the three #10 wood screws, then attach the nut with the screws. Thread the vise screw back through the chop and leg and engage the nut to test the action. The vise should now work sweetly. Sometimes, depending on how much toe-in you have, or how accurately you milled your leg and chop, the nut might bind on the screw when you operate the vise. This is usually caused by the nut being out of parallel with the screw. Loosening the screws that hold the nut to the back of the leg is usually the solution. These screws do not need to cinch the nut to the leg tightly for the vise to operate properly. Leaving the nut just this side of tight (so it can float around just a tad) will allow the vise to operate very sweetly.

INSTALL THE ACETAL BUSHING

The acetal bushing, which stabilizes the chop, is installed next. The bushing's hole is milled to be just a few thousandths larger than the screw's width, helping stabilize left-right movement during operation of the vise. Unthread the screw from the nut, then pull on the handwheel until the end of the screw clears the front of the leg (you don't need to separate the Crisscross arms.) Slip the bushing over the end of the screw with the counterbores facing out. Then feed the screw back through the leg and engage it in the nut a few turns. Orient the bushing so the elongated hole is vertical See illustration.

With the bushing pressed against the face of the leg, shift the chop back and forth so you can observe the position of the bushing. You want to find the center of that left-right movement. Once you've got it, position the bushing up/down so the elongated hole is positioned equidistant from the screw on top and bottom-you want an equal gap top and bottom. Trace the perimeter of the bushing onto the face of the leg with a pencil. Unthread the screw, remove the Crisscross from the leg and then prepare to excavate the mortise for the bushing. The bushing itself is 2-1/2" diameter, but you'll want to make the mortise larger than this, at least 2-5/8" diameter. This allows you to adjust the position of the bushing once

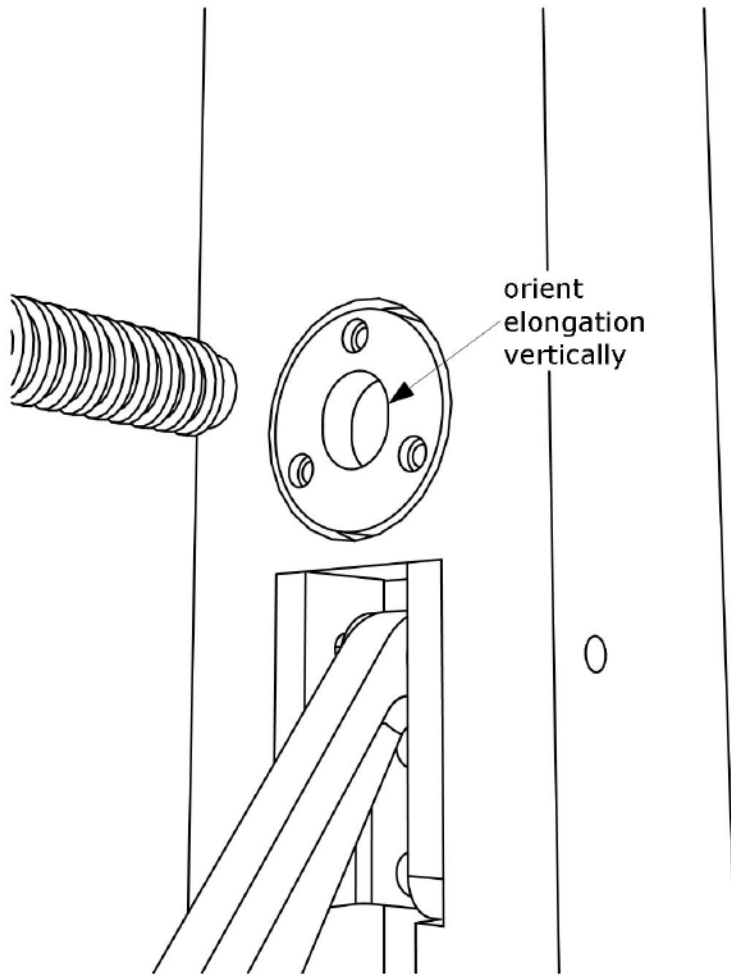

its attached to the leg. You can drill this mortise with a Fortsner bit, circle-cutting jig and router, or with a fly cutter, followed by simply drilling or routing out the interior. The perimeter doesn't have to be a perfect circle. You don't want the bushing to be proud of the leg's surface, so make the mortise at least 9/16" deep. Reassemble the vise and advance the screw a few turns into the nut. Move the chop back and forth (left and right) until the bushing is centered in the mortise, and also centered vertically. Use a transfer punch (or bradpoint bit) to mark the location of the mounting screws through the bushing while keeping the chop still. Remove the bushing, then drill pilot holes for the #8 wood screws, reinstall the bushing and

attach it with the screws, but keep them a bit loose for now. Test the action of the vise with the bushing in place. The vise screw should turn freely and smoothly. Tighten one of the bushing screws and test again. Now gradually tighten the remaining screws incrementally while turning the vise screw. If you feel the vise screw getting tighter as you tighten each bushing screw, loosen the bushing screws and start again. The bushing is there to provide stability, it should not hamper the rotation of the vise's screw. It's also very important that the bottom of the mortise be flat. If it's not, the bushing will be distorted as you tighten the screws, possibly binding the main screw. If you need to remove more material from the bottom of the mortise to get it flat, do so. It doesn't matter if the bushing is slightly recessed into the leg a bit.

FINAL STEPS

Once the Glide is completely installed and functioning smoothly, mark and cut the chop to final length, flush with the benchtop. You can chamfer the top corner of the chop or round it over. This is also a good time to glue on the Crubber. Contact cement, hide glue, and white or yellow carpenter's glue works fine. The Crubber is an important part of the Glide. It provides incredible holding power with little effort. We line all of our vises with this material, including the faces of our bench dogs. You can purchase Crubber at our website.

To install the knobs, place a shoulder bolt through the knob and slip on the thick washer/spacer on the threaded end. Screw it in place on the handwheel. The knob is designed to spin freely on the bolt. If you'd rather have the knob not rotate, place one of the nylon washers under the head of the shoulder bolt before inserting it in the knob. This will allow the bolt to clamp down tight onto the knob preventing rotation.

Once you've finished these steps and reassembled everything you can enjoy your Glide Leg Vise. Grab some boards and a hand plane and give it a go. The knobs are very handy for spinning the vise quickly for rapid and gross adjustments. But for repetitive clamping and unclamping of similar thickness workpieces---edge jointing panels or cutting numerous tenons for door frames for example--grasping one knob or the rim of the handwheel and giving the vise about a 1/3 turn is all that's necessary to open the jaw and regrip. With a knob at each 120 degree location, you will always have a knob within easy reach at the top of the wheel, anywhere between the 10 o'clock and 2 o'clock positions. Experiment with how much force is really necessary to hold your workpiece securely. You'll find it's much less than you initially think, making workholding even more effortless as you learn to use the Glide.

The steel and iron parts of the vise can rust. You can treat your Bench-crafted vise like any fine handplane. Keep dust and moisture from the mechanism and you'll be set. Periodically lubricate the screw threads and between the handwheel and flange with dry-type bicycle chain lubricant. Just a few drops usually does it.

We want your vise to operate perfectly and we're here to make sure you get it installed to your satisfaction. If you need assistance, write us at technical@benchcrafted.com

Addendum

Tapping Holes In Wood For Machine Screws

Aside from the typical woodworking tools required to build the wood components of the vise and install it, you'll need a machine screw tap to install the machine screws in the flange, and Retro brackets. Many of you will already have this tap, and for those who don't, you'll be able to pick them up at any hardware store or home center. Mail order suppliers like Enco or McMaster will also have taps. Taps are inexpensive.

To attach the flange to the chop you'll need a 5/16-18 bottoming tap. Standard plug taps will work fine, but bottoming taps (they cut threads almost to the bottom of a hole) will require a shallower hole. Not a huge issue for the flange holes, but for the Retro, especially in the chop, you'll want to use a bottoming tap, ideally. Pilot hole size for 5/16-18 is 1/4", or a tad less like 15/64 if you have it.

The holding power of machine screws in wood is about the same as using a threaded insert, and you don't have to buy the inserts. It's also a great technique for making jigs and knock-down joints.

Once you drill the pilot hole (use a drill press for accuracy if possible) chuck the tap in a small, cordless, variable-speed driver with the torque set for driving screws (the slower setting). Hold the drill perpendicular to the surface and without pushing on the drill (just support its weight while keeping it square) press the trigger and let the tap feed itself into the hole slowly. It helps to cut a small countersink in the pilot hole to help get the tap started. When you feel the tap tighten up a bit and you've reached the depth of threads you're after, release the trigger. Switch the drill into reverse and press the trigger without pulling on the drill. Let the tap thread itself out of the hole slowly. It's important to go slow and feel how the tap is working. If you go too fast you risk binding the tap. At that point the tap becomes a drill bit and you just end up making a larger hole. If you're new to this, practice on some scrap first. You can also tap the holes by hand, but once you get the hang of using the driver it makes tapping quick and easy.

**Dimension X will vary depending on your bench height*

*** Others' bench hardware may vary*

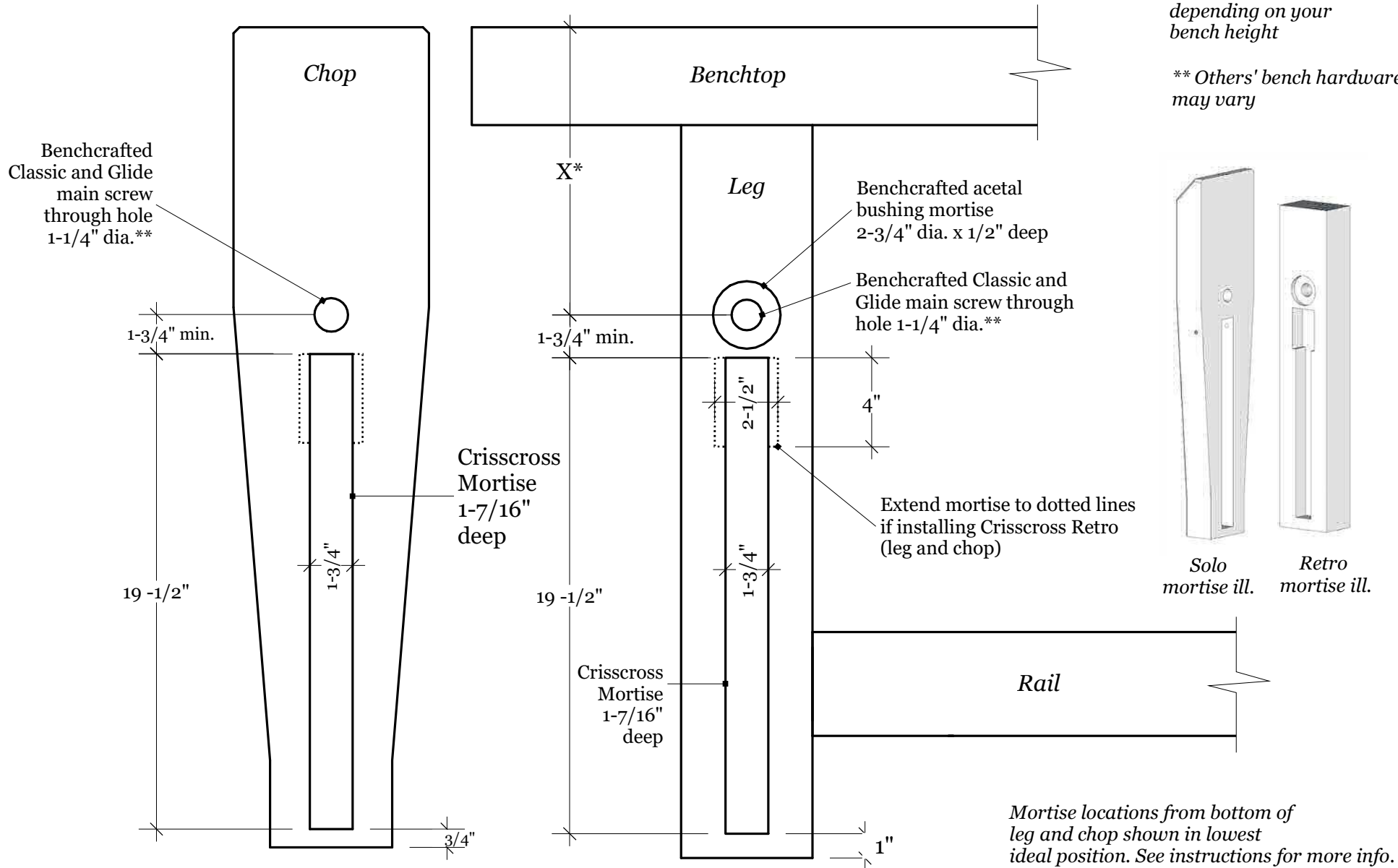

**CRISSCROSS
MORTISE DEPTH:**

$1 - 7/16"$ in both chop and leg

Crisscross		Leg And Chop Layout	
<small>Copyright 2018 Benchcrafted No unauthorized duplication without permission.</small>		<small>Scale: not to scale</small>	<small>Page: Version: Jan 2015</small>



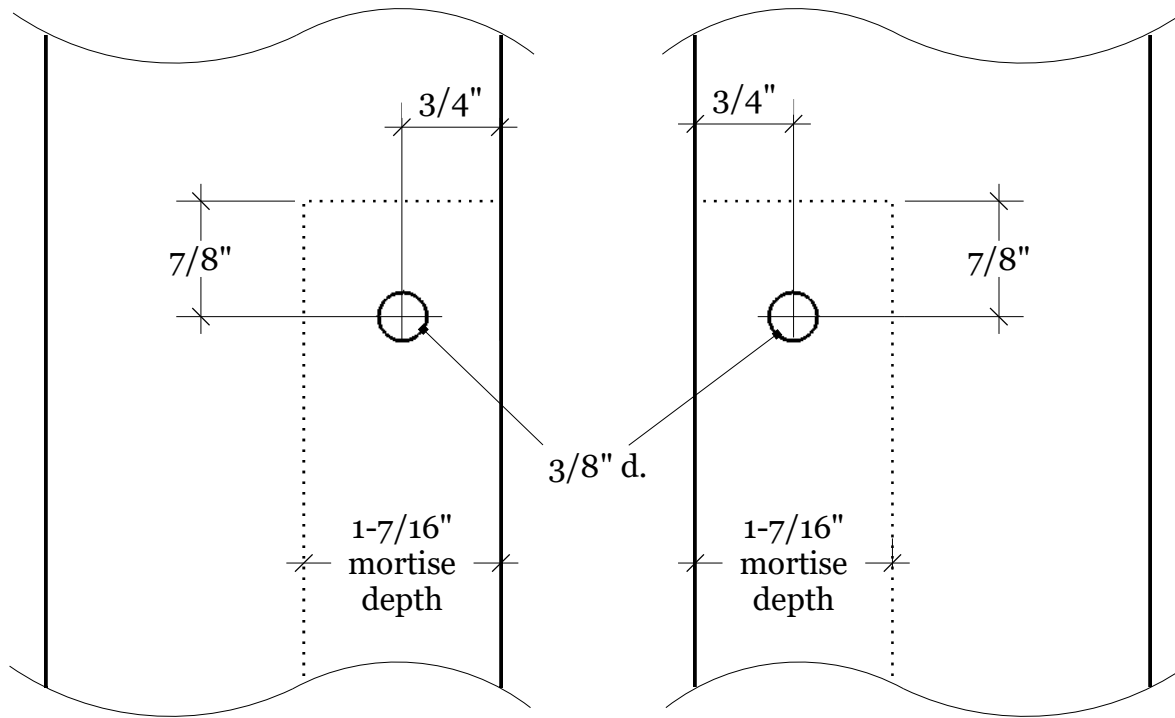



Chop

Leg

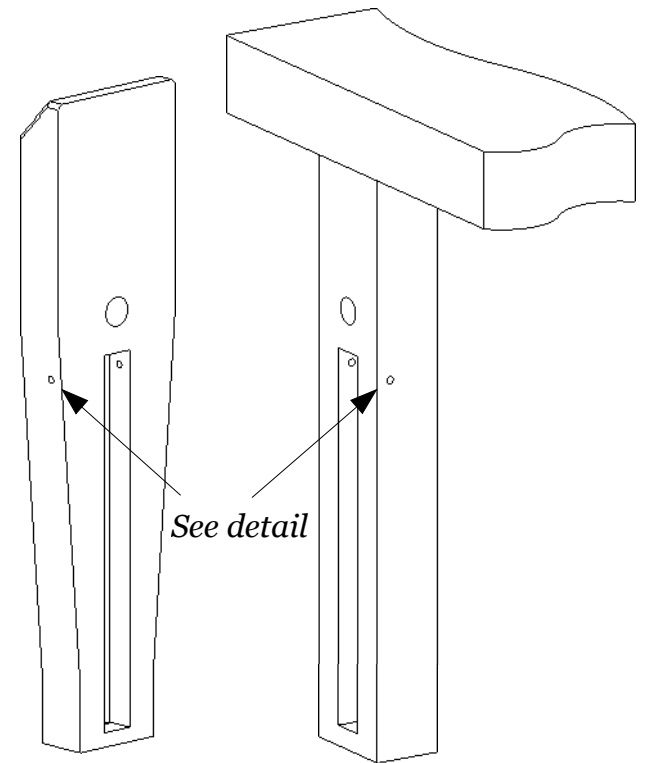
Detail



Crisscross Solo		Mounting Pin Location		
Copyright 2018 Benchcrafted No unauthorized duplication without permission.		Scale: nts	Page:	

Cut on both ends of front rail.

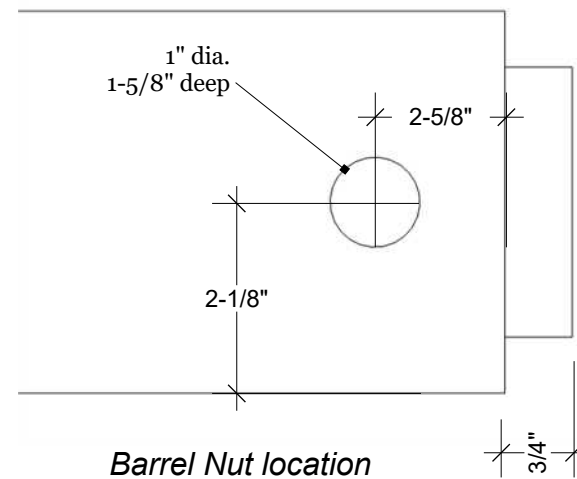
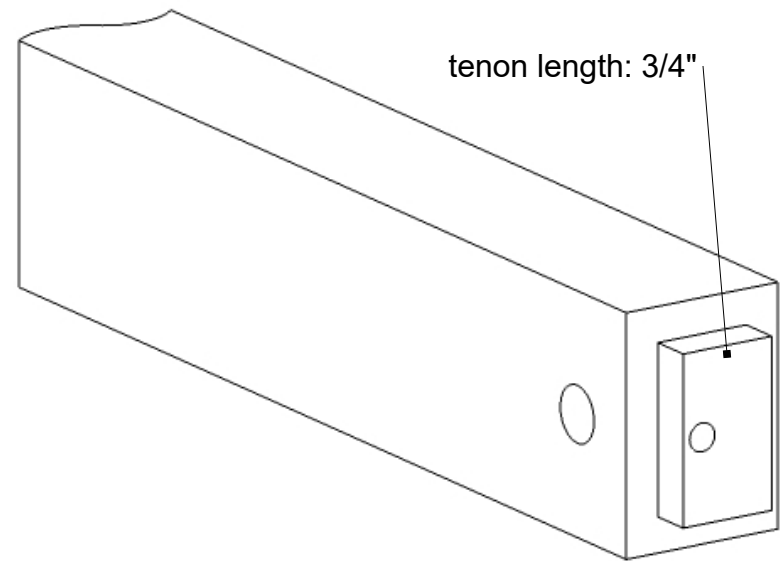
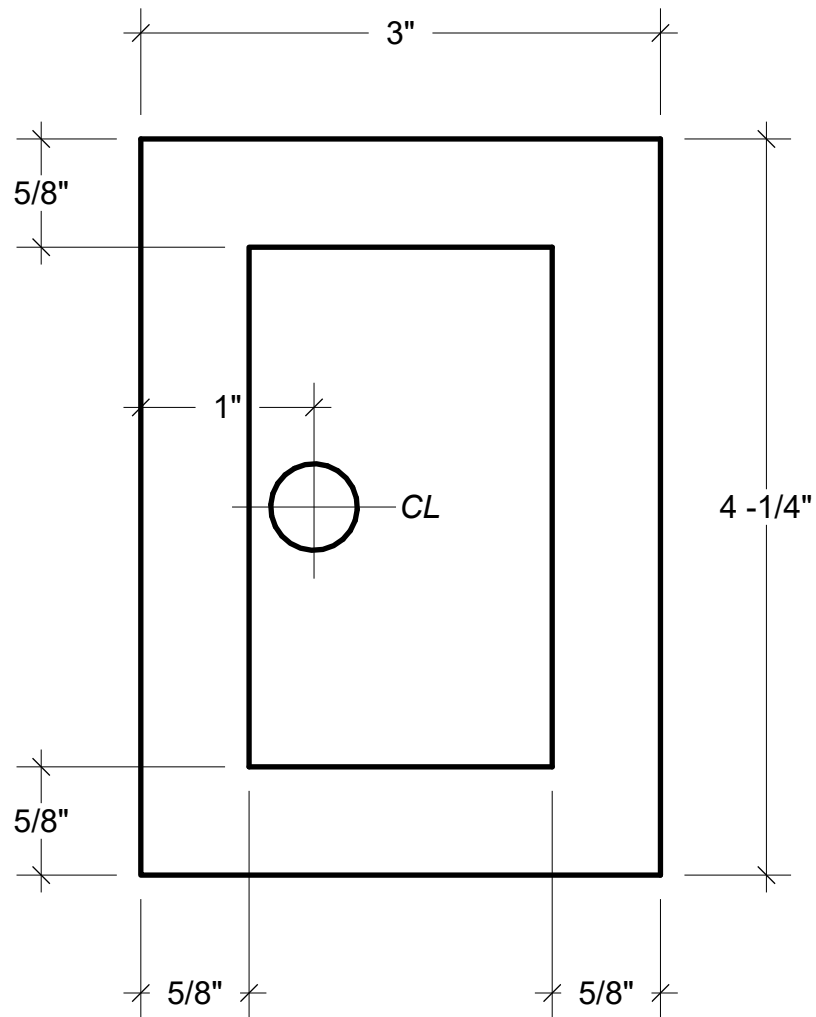

This template is taken from our Split Top Roubo Bench plans and represents a suggested way of joining a front rail to a leg in a Roubo-style bench to accommodate the Crisscross and our Barrel Nut hardware. Your bench configuration may be different.

Crisscross		Front Rail Tenon		
Copyright 2012 Benchcrafted No unauthorized duplication without permission.		Scale: nts	Page: 1:1	

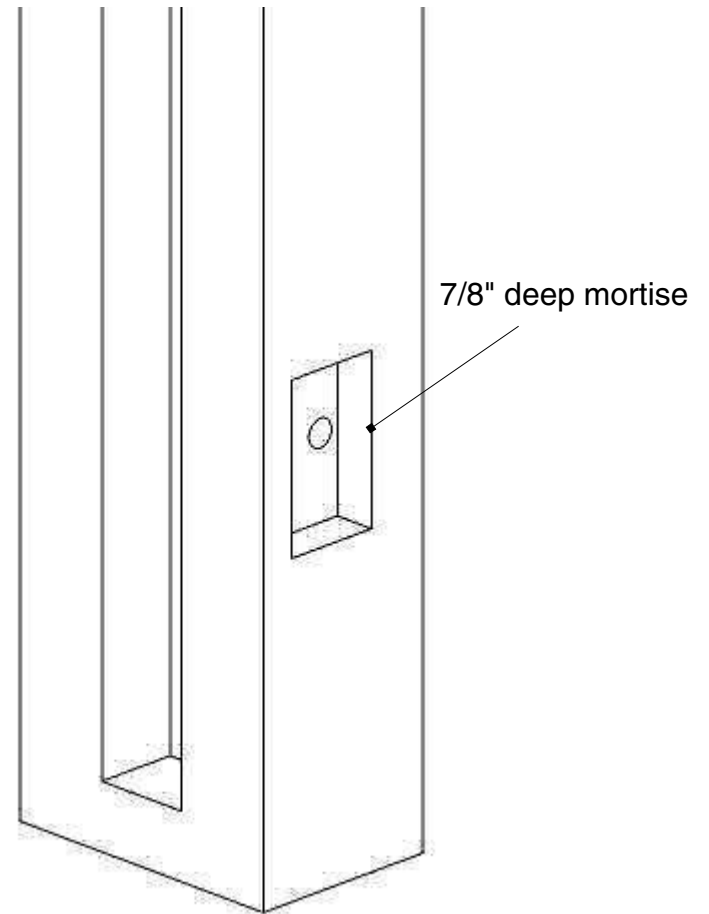
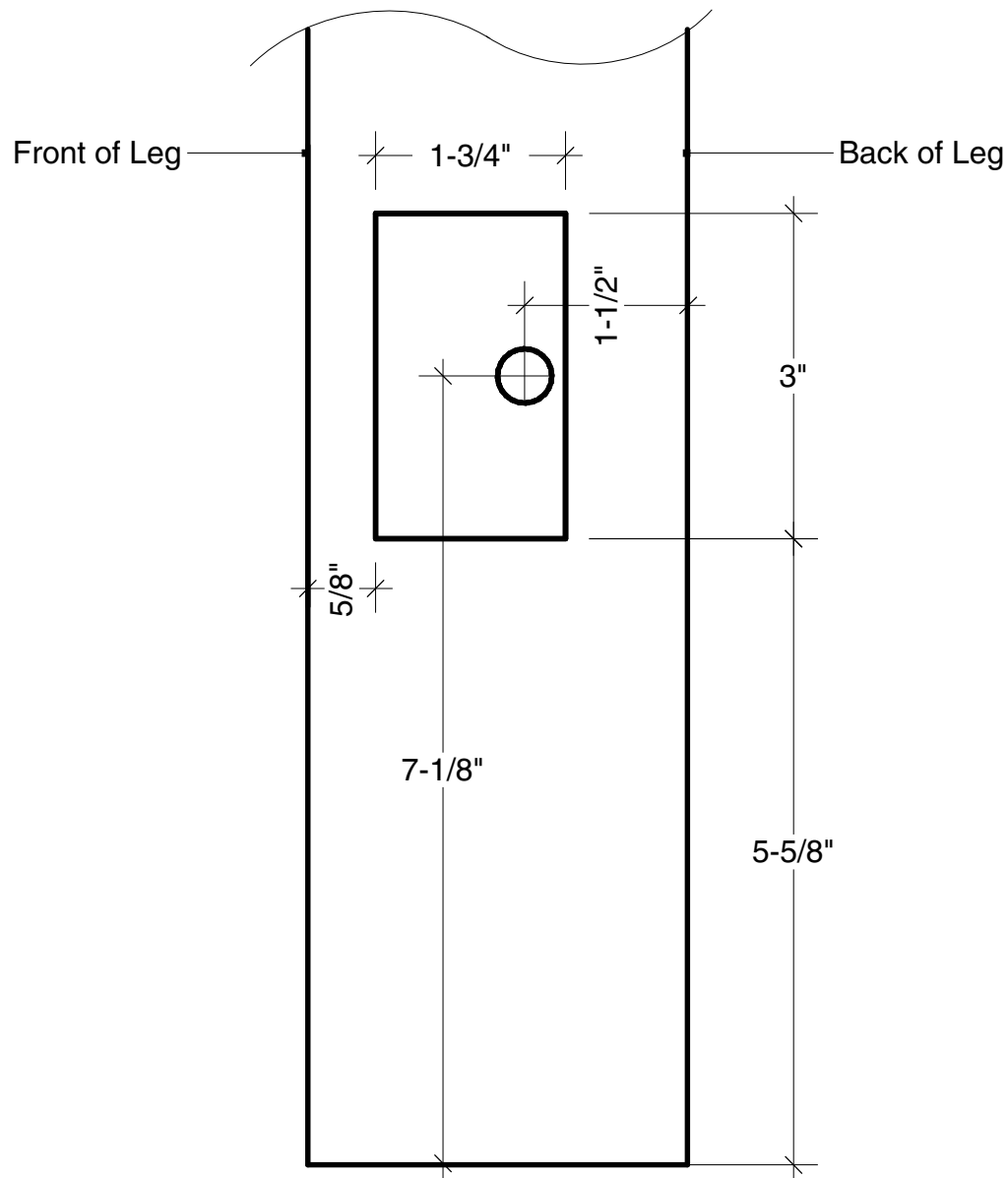

*Leg Vise leg shown (w/ Crisscross mortise.)
Cut mirror-image rail mortise on
opposite front leg.*

This template is taken from our Split Top Roubo Bench plans and represents a suggested way of joining a front rail to a leg in a Roubo-style bench to accommodate the Crisscross and our Barrel Nut hardware. Your bench configuration may be different.

Crisscross	Front Rail Mortise			
Copyright 2012 Benchcrafted No unauthorized duplication without permission.	Scale: 1:1	Page: 1:1	Version: Rev 1	

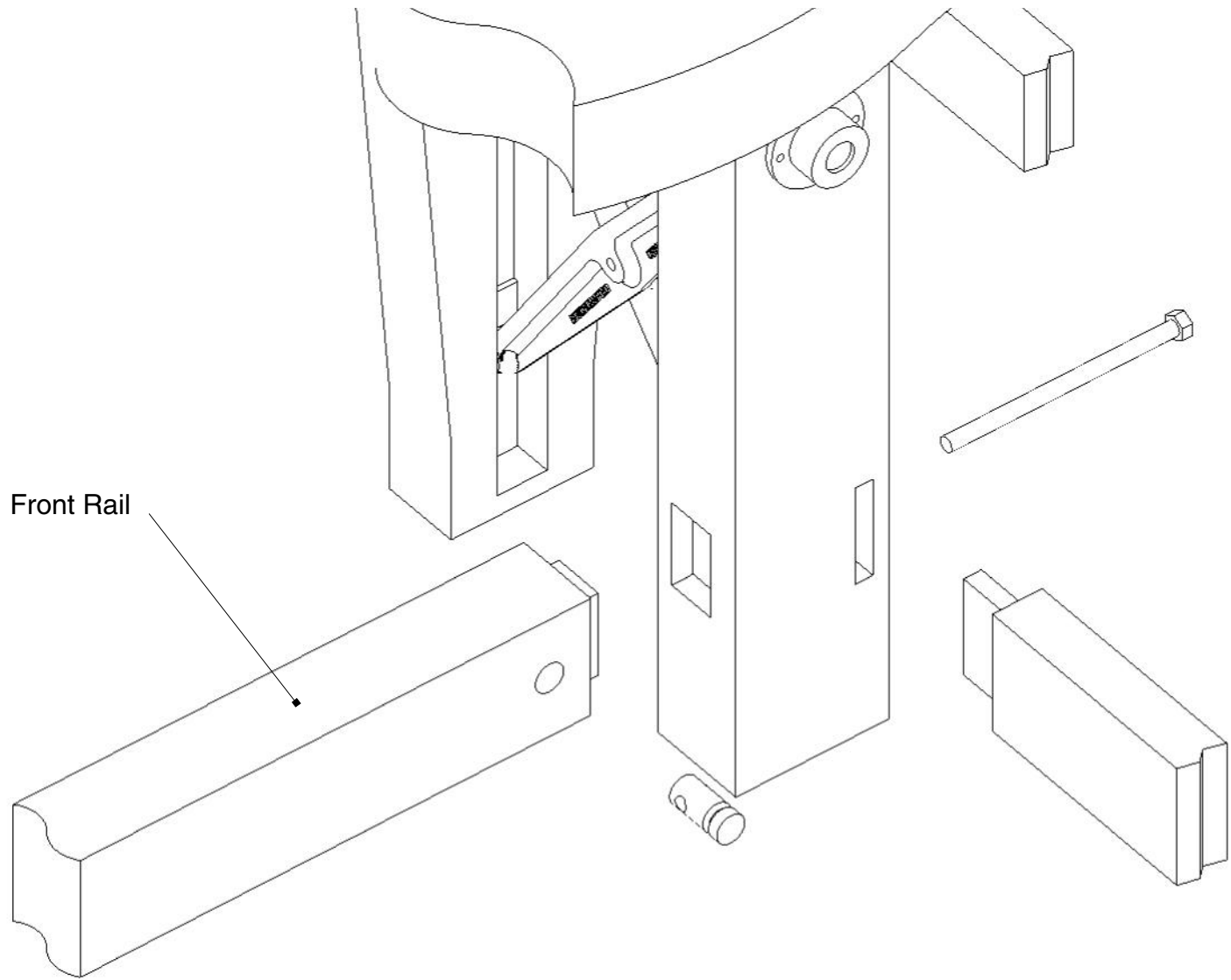

Front Rail

This illustration is taken from our Split Top Roubo Bench plans and represents a suggested way of joining a front rail to a leg in a Roubo-style bench to accommodate the Crisscross and our Barrel Nut hardware. Your bench configuration may be different.

Crisscross	Vise Leg Joinery		
<small>Copyright 2012 Benchcrafted No unauthorized duplication without permission.</small>	Scale:	Page:	Version:



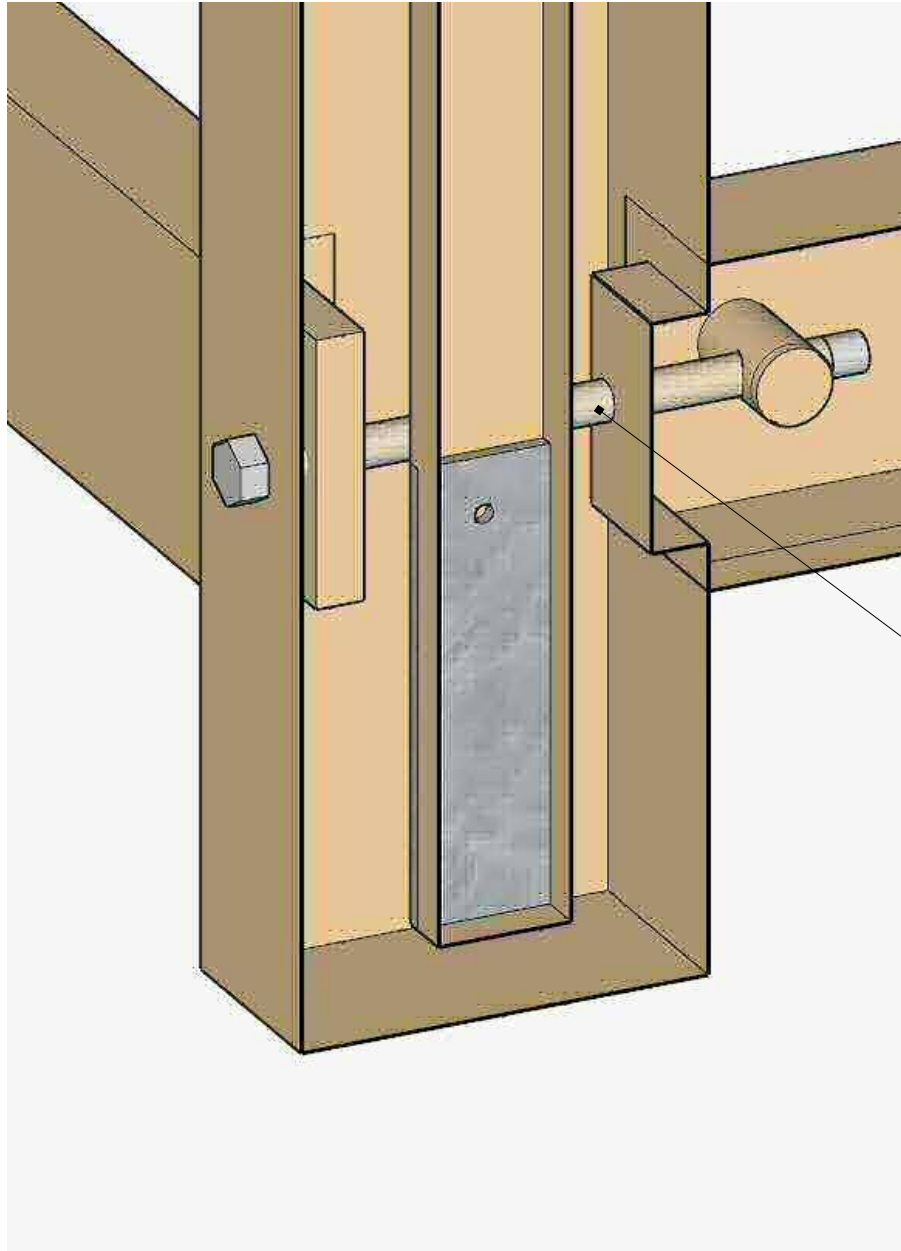

Bolt passes behind Crisscross mortise to engage barrel nut in front rail

This illustration is taken from our Split Top Roubo Bench plans and represents a suggested way of joining a front rail to a leg in a Roubo-style bench to accommodate the Crisscross and our Barrel Nut hardware. Your bench configuration may be different.

Crisscross	Leg Joinery X-Section			
<small>Copyright 2014 Benchcrafted No unauthorized duplication without permission.</small>	Scale:	Page:	Version:	