

JB-250

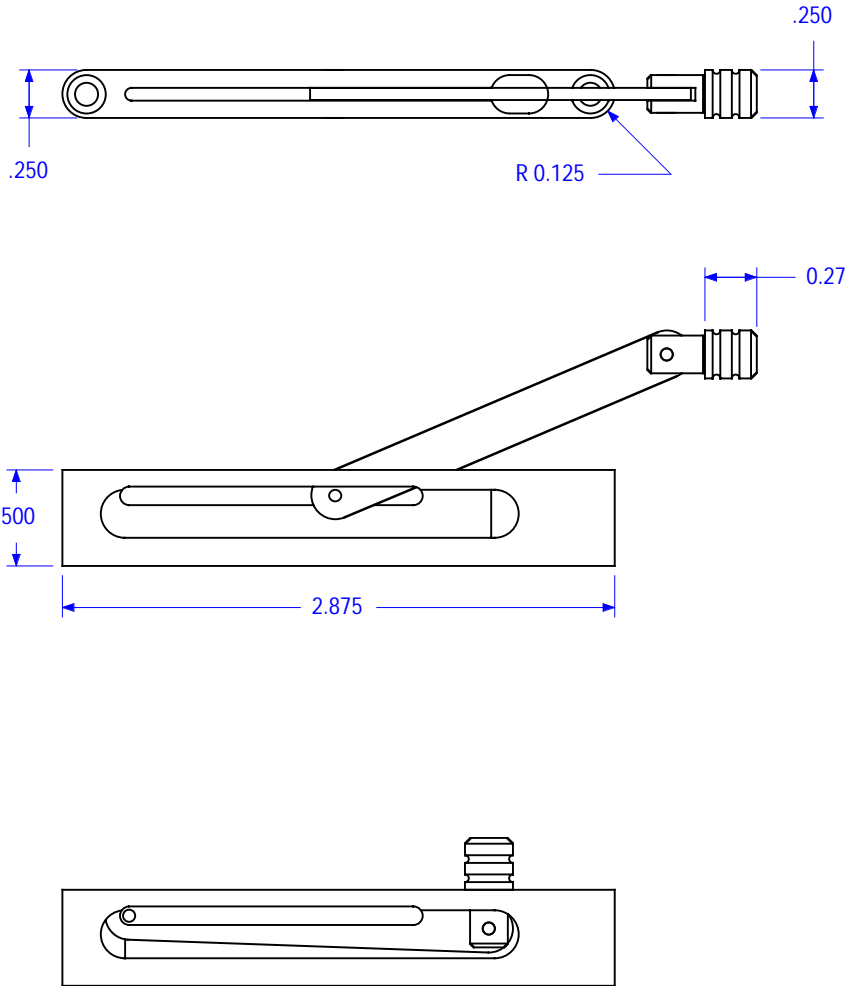

Do not scale drawing

Questions- Call before mortising 212-337-8510

BRUSSO ® <i>Incorporated</i> PRECISION HARDWARE	© 1983-2003 Brusso Inc. 20 Vandam Street New York, NY 10013 212 337 8510 Fax 212 337 9840	Product: JB-250 Lid Stay			Revision: a
		Component: Template			File Name: JB-250 Lid Stay -Rev a
Tolerances unless otherwise specified: Machined features fraction +/- 1/64, Decimal .XXXX +/- .0005, .XXX +/- .005, Angular +/- 1 Degree, Hole Diameter +.003/-.002		Catalog Number: JB-250	Drawn by: JM	Checked by: AS	Sheet: 1 of 6
		Scale: 1:1	Date: 06/13/03	Date: 06/24/03	